

# FioSonic

Industrial metering



**TECHNICAL BROCHURE**

**Pietro Fiorentini S.p.A.**

Via E.Fermi, 8/10 | 36057 Arcugnano, Italy | +39 0444 968 511  
sales@fiorentini.com

The data are not binding. We reserve the right  
to make changes without prior notice.

FioSonic\_technicalbrochure\_ENG\_revA

**[www.f Fiorentini.com](http://www.f Fiorentini.com)**

# Who we are

We are a Global organization specialized in designing and manufacturing technologically advanced solutions for natural gas treatment, transmission and distribution systems.

We are the ideal partner for operators in the Oil & Gas sector, with a business offer that goes across the whole natural gas chain.

We are in constant evolution to meet our customers' highest expectations in terms of quality and reliability.

Our aim is to be a step ahead of the competition, with customized technologies and an after-sale service program undertaken with the highest grade of professionalism.



## Pietro Fiorentini advantages



Localised technical support



Experience since 1940



We operate in over 100 countries

# Area of Application

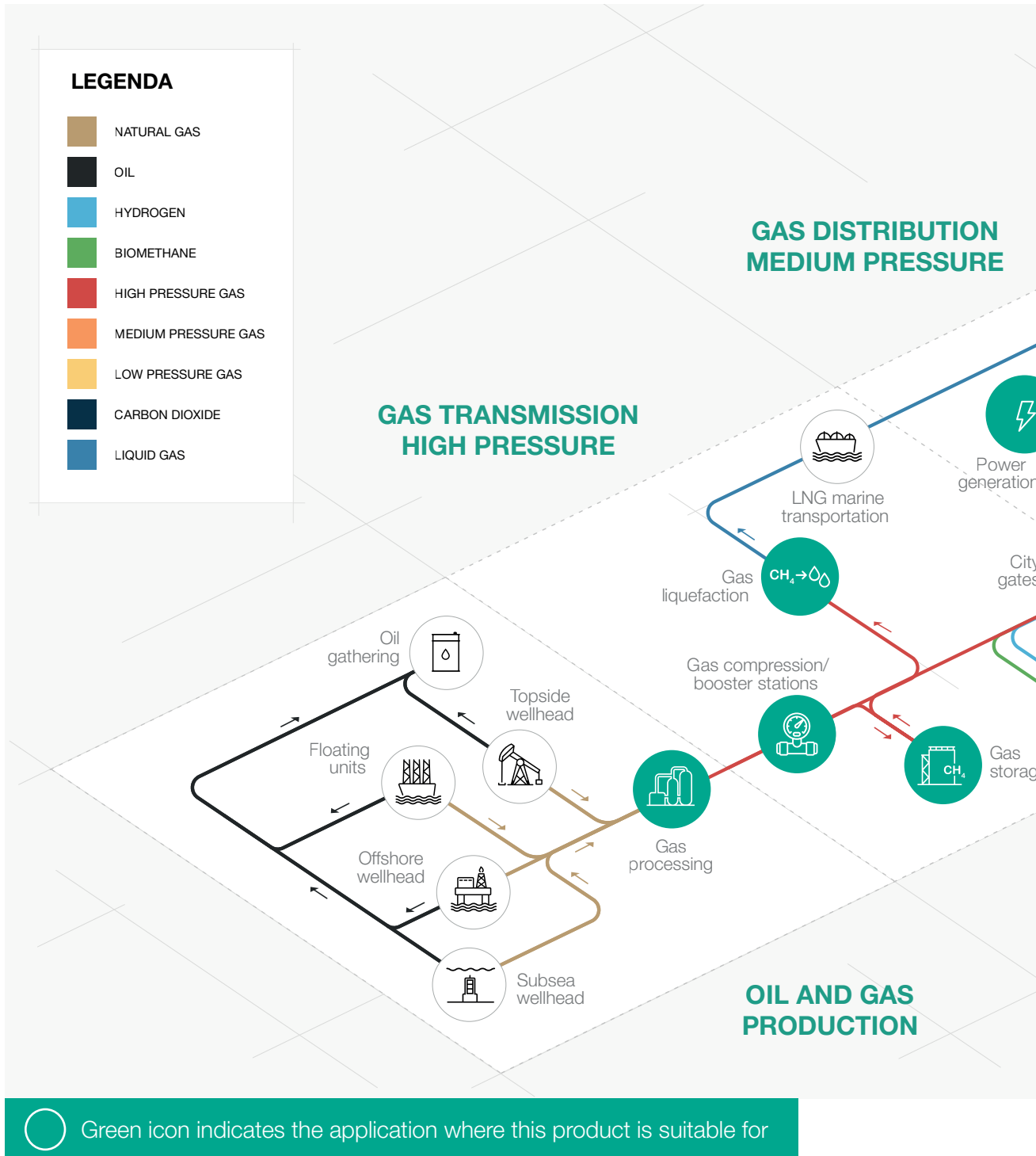

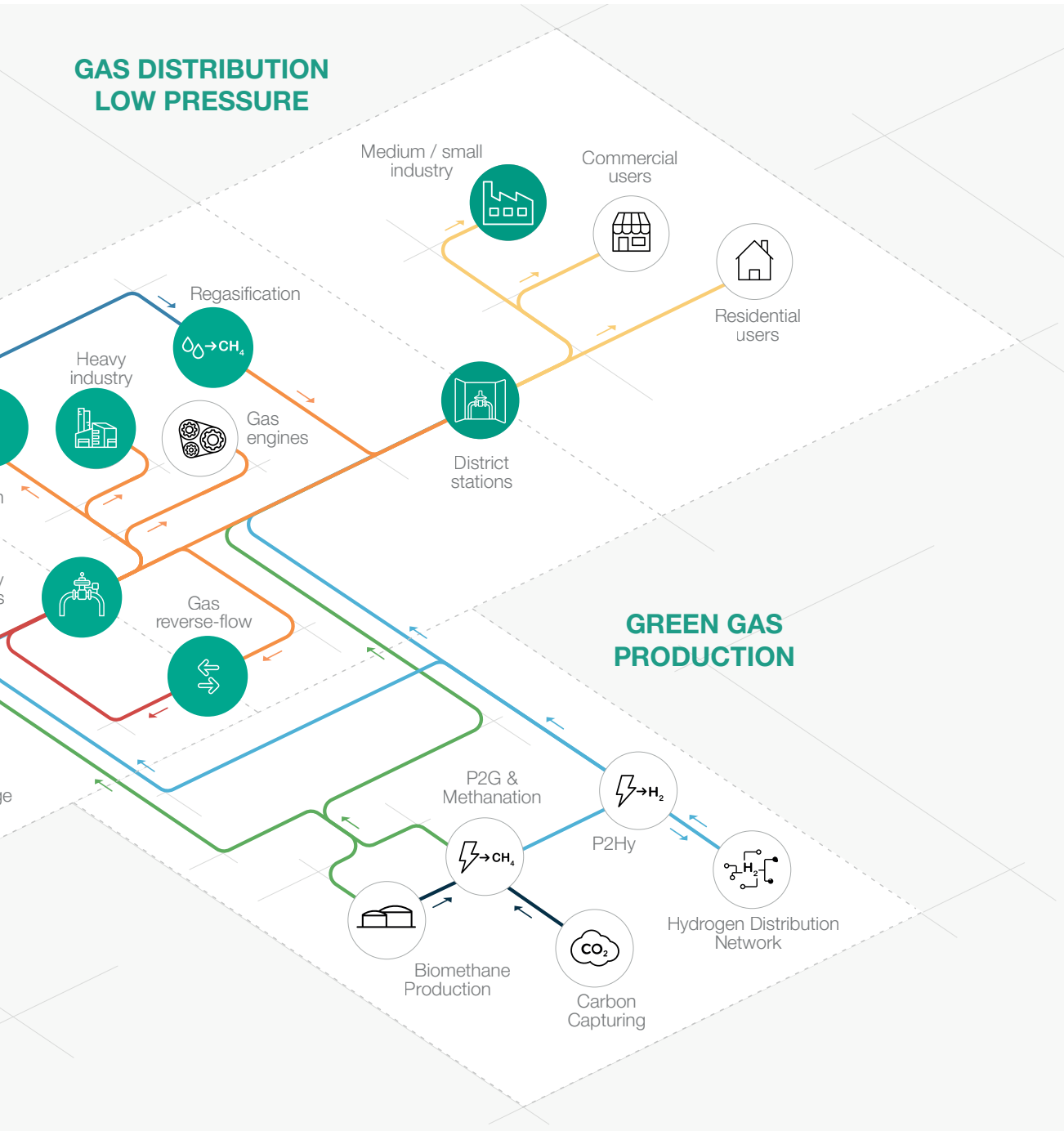

**Figure 1** Area of Application Map



# Introduction

**FioSonic** is the natural evolution of the Pietro Fiorentini know-how and experience in the gas industry.

With its multi path-chordal ultrasonic technology **FioSonic** provides real time diagnostics high accuracy and redundancy for custody transfer gas flow measurement.

This device is mainly used for high-pressure transmission systems, power plants, heavy industry and for medium - low pressure natural gas distribution networks, from 5 KPa(a) | 0,05 bar(a) to 15.3 MPa(a) | 153 bar(a) of pipeline operating pressure.

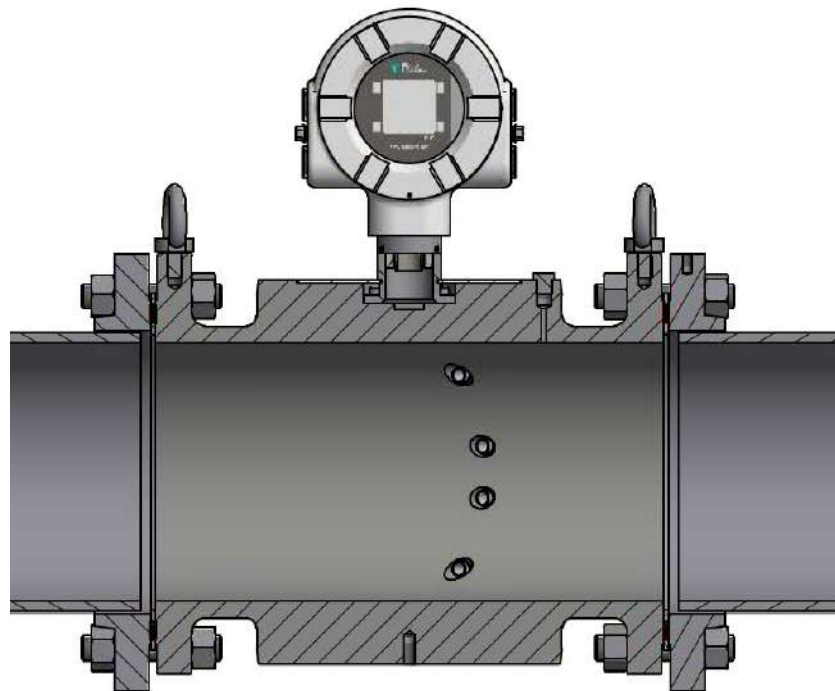

**Figure 2** FioSonic - Ultrasonic Gas Flow Meter

# Features

**FioSonic** Series standard product has three or four paths, depending on measurement purpose. This design guarantees stable accurate flow reading over the full range of flow, pressures and gas compositions.

The Broadband Continuous Wave signal processing allows more than one path to be interrogated simultaneously avoiding the slow response typical of first generations of ultrasonic meters.

**FioSonic** transducers frequency is from 100-250 kHz depending on the meter's size to guarantee the best performances..



**Figure 3** FioSonic



**Figure 4** FioSonic BX

## Natural Gas blended with Hydrogen

The **FioSonic** is suitable for use with Natural Gas with up to 30% of Hydrogen blending.



## Titanium transducers

The titanium ultrasonic sensors are remarkably efficient and coupled with the Broadband Continuous Wave processing can reliably measure the most challenging applications such as wet and dirty gases. The combination of the efficient transducers and the Broadband Continuous Wave processing is also resistant to acoustic noise such as valve noise which has been the bane of other ultrasonic meters.

The power efficient design of the ultrasonic transducers allow them to operate at the very low transmitting voltage of 3.6V compared to tens or even hundreds of volts required by other manufacturers.

All wetted surfaces are metallic to provide the best resistance against the harshest conditions.. Transducers are available up to 15.3 MPa(a) | 153 bar(a) versions. Transducers Extraction Tool intended for transducers removal under pressure (Max 10 MPa | 100 bar(g)) is available as option on sizes above DN 200 (8”).

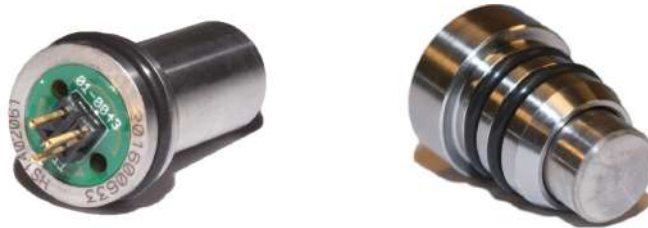

**Figure 5** Ultrasonic Transducers

## BCW - Broadband Continuous Wave signal processing

Most ultrasonic flow meters transmit a short burst of ultrasonic energy consisting of between one and four pulses or cycles.

A few ultrasonic meters use a short code typically much less than 100 cycles.

The **FioSonic** flow meter transmits many thousands of cycles in an almost continuous stream of encoded pulses. At the receiver the signal is decoded in real time to reconstruct the receive signal that is precise and resistant to signal noise and interferences in difficult applications.



The Broadband Continuous Wave system allows transmission of two or more paths at the same time without interferences. Simultaneous transmission means a faster response time and a better performance in fluctuating or pulsating flow conditions.

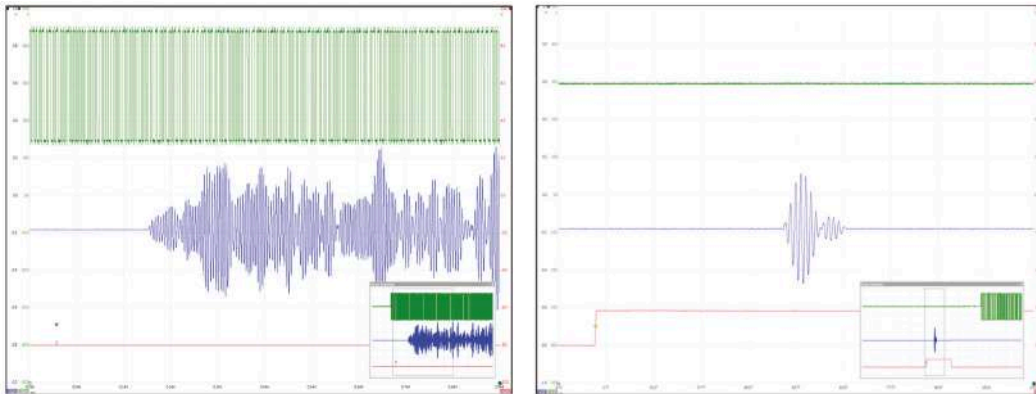

**Figure 6** - Left: Encoded Transmitted Signal (green) and received signal (blue)  
Right: Decoded receive signal (blue)

## Simplified design

Having all on-board electronics on a single circuit board FioSonic offers simple design and maintenance.



**Figure 7** On-board electronics



## Additional boards

### Extended I/O board

The **FioSonic** Series comes standard with the Pulse/Frequency output and a USB port for commissioning and field service. Optional I/O Boards can provide an isolated RS485 and two additional isolated Pulse-Frequency outputs and 4-20mA.

### Pressure and temperature input board

For applications requiring integrated volume conversion the FioSonic flowmeter is capable of interfacing directly with pressure and temperature sensors. The standard volume flow is calculated using the traditional volume conversion equations using fixed parameters for gas composition.

## Flow computer connectivity

**FioSonic** meter can be connected to all major flow computer brands available in the market either with pulses or serial line (Modbus protocol).

### Environment Protections

The **FioSonic** Series epoxy coated aluminum alloy electronic housing rated to IP66 and NEMA 4X is designed to be used outdoor in almost any environment.

The ambient operating temperature covers the range  $-40^{\circ}\text{C}$  to  $+60^{\circ}\text{C}$  |  $-40^{\circ}\text{F}$  to  $+140^{\circ}\text{F}$ . The ultrasonic sensors have all titanium wetted surfaces and are designed for process gas temperature from  $-30^{\circ}\text{C}$  to  $+80^{\circ}\text{C}$  |  $-22^{\circ}\text{F}$  to  $+176^{\circ}\text{F}$ .

### Intrinsically Safe Design

The FioSonic has a fully Intrinsically Safe design (Exia) for both transducers and electronic board components.

This design increase the safety and allow the maintenance without interruption of gas measurement.

### Diagnostic and performance monitoring

The FioSonic series provide extensive diagnostic information both on the graphic display screen and remotely via the PF Instruments Manager PC interface.

Flow information and diagnostics may be logged over time to show trending and enabling real time condition monitoring.









The velocity profile is a function of the upstream pipework. By calculating velocity ratios between the ultrasonic paths a good indication of the flow profile is realized. The flow meter calculates Profile and Symmetry Factors which can be used for condition monitoring of the measurement and the gas flow. In addition the FioSonic flow meter provides diagnostics for turbulence by means of the standard deviation of the instantaneous path velocity measurements.

The standard deviation provides an excellent diagnostic for turbulence fluctuations and may serve as an indicator of upstream disturbances. Additional meter diagnostics such as velocity of sound signal-to-noise ratio and signal strength are available to the user as well.





## FioSonic competitive advantages

-  Titanium transducers for long durability
-  BCW processing for reduction of noise interferences
-  Low voltage sensors
-  Easy maintenance
-  No moving parts
-  30% Hydrogen blending compatible. Higher blending available on request
-  1:160 High rangeability
-  Metallic wetted parts
-  Bi-directional Flow measurements

## Features

Features	Values
Design pressure*	up to 15.3 MPa(a) up to 153 bar(a)
Ambient temperature*	<ul style="list-style-type: none"> <li>Ambient Temperature for Non custody Transfer: from -40 °C to +60 °C from -40 °F to +140 °F</li> <li>Ambient Temperature Custody Transfer (MID and OIML certified): from -25 °C to +55 °C from -13 °F to +131 °F</li> </ul>
Operating (gas) temperature*	from -30 °C to +80 °C from -22 °F to +176 °F
Accuracy	Up to 0.5% with factory calibration Up to 0.2% with high pressure flow calibration
Rangeability	Up to 1:160 for non-custody transfer Up to 1:125 for custody transfer acc. to OIML R-137/MID
Repeatability	0.1%
Ingress Protection	IP 66 / NEMA 4X
Applicable metrology standards	AGA-9; OIML R137-1&2 ; MID 2014/32/EU
Power supply and consumption	Main power: 14 - 0,710 mW max I/O option board power: 10.8 - 1,626 mW max
Hazardous area certification	ATEX II 1 G Ex ia IIC/IIB T4 Ga (intrinsically safe) IECEX Ex ia IIC/IIB T4 Ga (intrinsically safe) cQPSus Class 1 Div.1 Gr. ABCD T4-T1 (intrinsically safe)
Accessories	Transducers Extraction Tool ≥ 8" (DN200)
Nominal dimensions DN	From DN80   3" to DN 750   30" for four-paths meter From DN50   2" to DN 750   30" for three-paths meter Above DN750   30" on request
Connections*	Class 150/300/600/900 RF / RTJ according to ASME B 16.5 or PN 16/25/40 according to EN 1092-1

**(\*) REMARK: Different functional features and/or extended temperature ranges available on request. Stated temperature ranges are the maximum for which the equipment's full performance, including accuracy, are fulfilled. Standard product may have a narrower range.**

**Table 1** Features

## FioSonic for Custody Transfer Flow Metering: four paths for enhanced accuracy and reliability

The FioSonic model “FSN-4P” has four paths. It has been designed and certified to meet the international standards for custody transfer metering including AGA-9, OIMLR137 1&2 (class 0.5-1) and MID class 1.

The integration of the flow across the paths provides accurate measurement even with varying flow profiles caused by changes in flow velocity, gas composition and pressure or upstream pipe configuration.

Fast response is maintained by the simultaneous transmission on more than one path using Broadband Continuous Wave processing.

The measured flow profile provides a diagnostic tool.

Should one path fail the Path Substitution Algorithm uses historical flow data to continue reliable flow measurements until the path recovers or remediation action is taken.

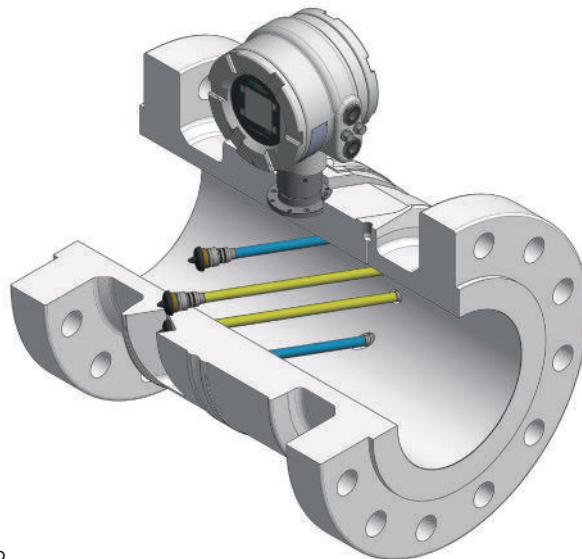

**Figure 9** FioSonic-FSN-4P



## FioSonic for Technical Metering: three paths

The FioSonic model “FSN-3P” has three paths as standard. It has been tested to meet the international standards AGA-9 and has an accuracy  $<1\%$ .

It is the ideal solution for any technical measurement focus on applications where measurement is required, but not necessary for custody transfer like pipelines branches, grid balancing or as input for gas network modeling.

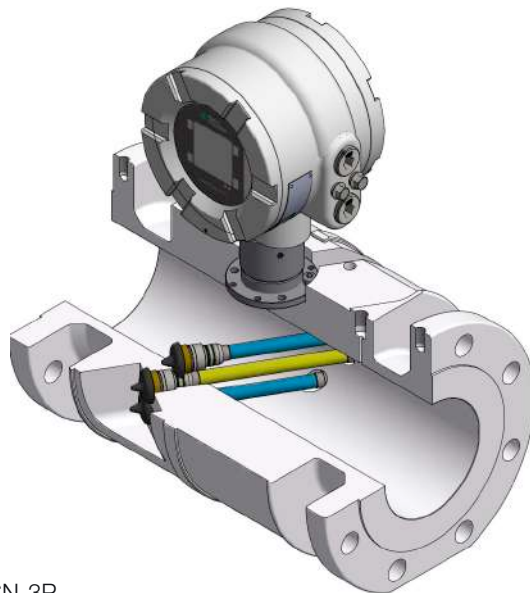

**Figure 10** FioSonic-FSN-3P

## FioSonic for redundant measurements applications

FioSonic BX series consists of two fully independent measurement systems integrated in one single standard meter body. This solution provides a remarkable space and cost saving. The meter can have 2 configurations:

- FioSonic BX model “**FSN-BX-4P-4P**” where both metering systems have 4 paths each. This solution is suitable for redundant custody transfer metering line.
- FioSonic BX model “**FSN-BX-4P-3P**” where 1 metering systems has 4 paths and 1 has 3 paths. This solution is suitable for only 1 custody transfer metering line with a second electronic as check.

Each metering system works independently without any signal synchronization maintaining the full range of versatile I/O.

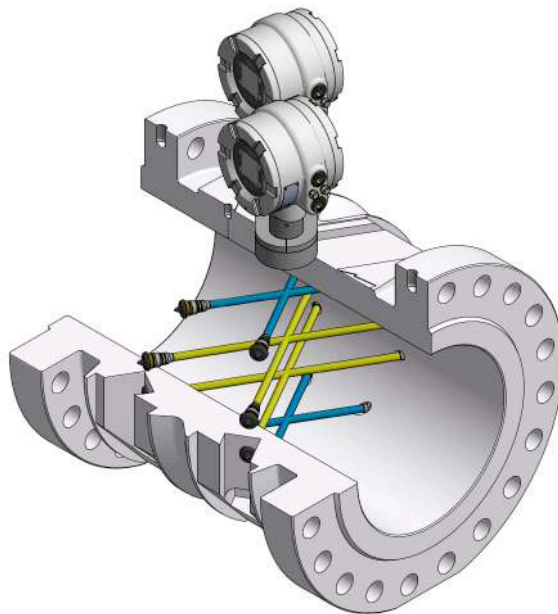

**Figure 11** FioSonic-BX-4P-4P



# Materials and Approvals

Part	Material
Body	Forged steel ASTM A350 LF2 Cl.1 Other material on request
Electronic enclosure	Epoxy painted low copper aluminum alloy Stainless Steel 316, on request
Transducers	Titanium ASTM B348 Ti GR.2
Sealing ring	FKM or other material according to process conditions

**REMARK: The materials indicated above refer to the standard models. Different materials can be provided according to specific needs.**

**Table 2** Materials

## Construction Standards and Approvals

The **FioSonic** is designed to meet AGA report N.9, ISO 17089-1, OIML R137-1&2 requirements.



AGA9



ISO17089-1

The product is certified according to European Directives 2014/68/EU (PED) as well as 2014/32/EU (MID), OIML R137 -1&2, ATEX, IECEx, CSA, UL (cQPS<sub>us</sub>).



OIML R137-1&2



PED-CE



MID



IECEx



cQPS<sub>us</sub>



ATEX



# Capacity table

Custody transfer measurement with OIML R137 -1&2 certification

Class 0.5 OIML R-137 FioSonic 4P Capacity table [pipe configuration 1 or 2]									
Nominal size		Pipe schedule	Capacity						
			Qmin		Qt		Q max		Turndown
Inches	DN	SCH	m3/h	cfh	m3/h	cfh	m3/h	cfh	1:X
2"	50	STD	-	-	-	-	-	-	-
3"	80	STD	9	300	60	2.100	601	21.200	67
4"	100	STD	15	500	99	3.400	991	34.900	66
6"	150	STD	27	900	99	3.400	2.014	71.100	75
8"	200	STD	35	1.200	99	3.400	3.487	123.100	100
10"	250	STD	55	1.900	99	3.400	5.492	193.900	100
12"	300	STD	79	2.700	99	3.400	7.878	278.100	100
14"	350	STD	96	3.300	99	3.400	9.608	339.200	100
16"	400	STD	127	4.400	99	3.400	12.728	449.400	100
18"	450	STD	163	5.700	99	3.400	16.285	575.000	100
20"	500	STD	203	7.100	99	3.400	20.280	716.000	100
24"	600	STD	296	10.400	99	3.400	28.597	1.009.700	97
30"	750	STD	468	16.500	99	3.400	43.700	1.543.000	93

**Table 3** Capacity and rangeability table

1 **PTB** flow conditioner piping configuration

2 **NOVA 50E** flow conditioner piping configuration

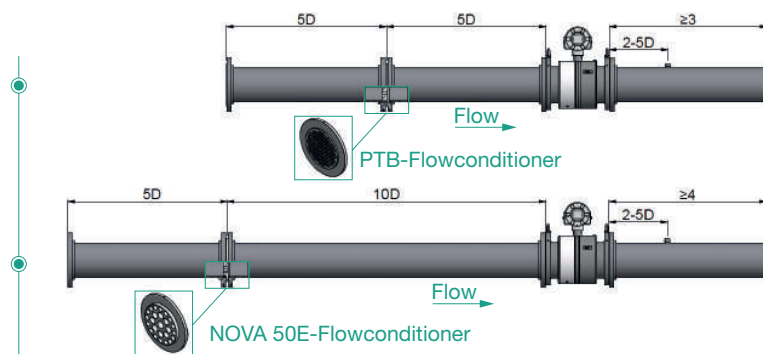



Custody transfer measurement with OIML R137 -1&2 or MID certification

**Class 1 OIML R-137 and MID class 1** FioSonic 4P Capacity table [pipe configuration 1 - 2 - 3]

Nominal size		Pipe schedule	Capacity						
			Qmin		Qt		Q max		Turndown
Inches	DN	SCH	m3/h	cfh	m3/h	cfh	m3/h	cfh	1:X
2"	50	STD	-	-	-	-	-	-	-
3"	80	STD	9	300	60	2.100	601	21.200	67
4"	100	STD	15	500	99	3.400	991	34.900	66
6"	150	STD	16	500	201	7.100	2.014	71.100	125
8"	200	STD	28	900	349	12.300	3.487	123.100	125
10"	250	STD	44	1.500	549	19.300	5.492	193.900	125
12"	300	STD	63	2.200	788	27.800	7.878	278.100	125
14"	350	STD	77	2.700	961	33.900	9.608	339.200	125
16"	400	STD	102	3.600	1.273	44.900	12.728	449.400	125
18"	450	STD	130	4.500	1.629	57.500	16.285	575.000	125
20"	500	STD	162	5.700	2.028	71.600	20.280	716.000	125
24"	600	STD	237	8.300	2.860	100.900	28.597	1.009.700	121
30"	750	STD	375	13.200	4.370	154.300	43.700	1.543.000	117

**Table 4** Capacity and rangeability table

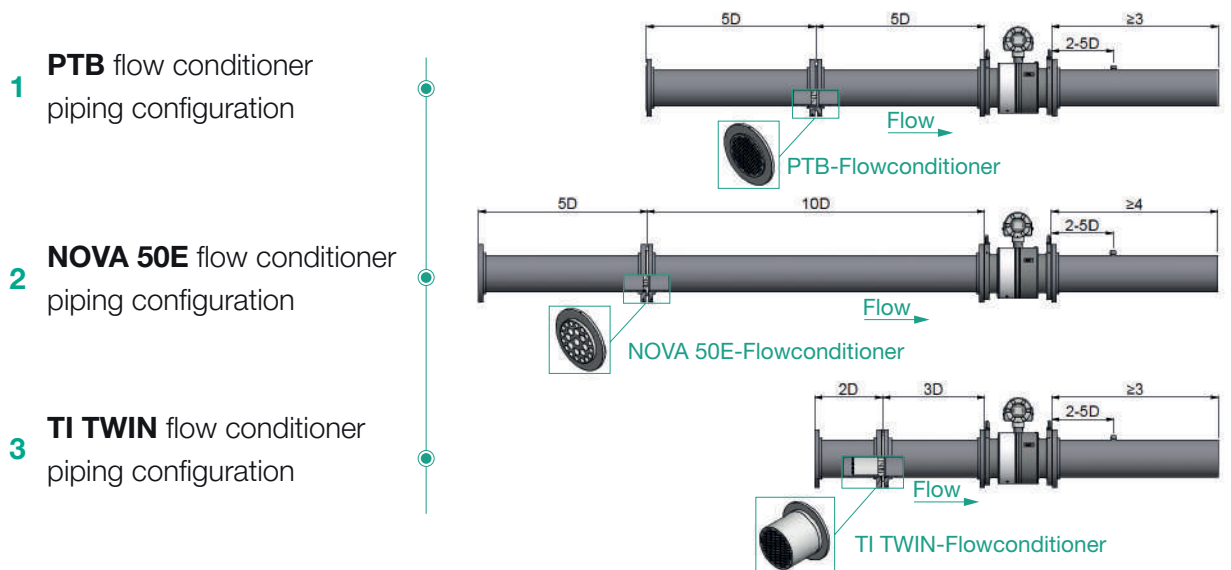

## Non Custody transfer measurement (technical measurement) without OIML R137 -1&2 or MID certification with accuracy up to 0.2%

FioSonic 3P and 4P extended range Capacity table [pipe configuration 1 - 2 - 3]									
Nominal size		Pipe schedule	Capacity						
			Qmin		Qt		Q max		Turndown
Inches	DN	SCH	m3/h	cfh	m3/h	cfh	m3/h	cfh	1:X
2"	50	STD	3	100	28	900	281	9.900	94
3"	80	STD	7	200	62	2.100	620	21.800	89
4"	100	STD	12	400	102	3.600	1.022	36.000	85
6"	150	STD	13	400	208	7.300	2.077	73.300	160
8"	200	STD	22	700	360	12.600	3.596	126.900	163
10"	250	STD	35	1.200	567	20.000	5.665	200.000	162
12"	300	STD	51	1.800	813	28.600	8.127	286.900	159
14"	350	STD	62	2.100	991	34.900	9.911	349.900	160
16"	400	STD	82	2.800	1.313	46.300	13.129	463.500	160
18"	450	STD	105	3.700	1.680	59.300	16.798	593.100	160
20"	500	STD	130	4.500	2.092	73.800	20.919	738.600	161
24"	600	STD	190	6.700	2.950	104.100	29.498	1.041.500	155
30"	750	STD	301	10.600	4.508	159.100	45.078	1.591.700	150

**Table 5** Capacity and rangeability table

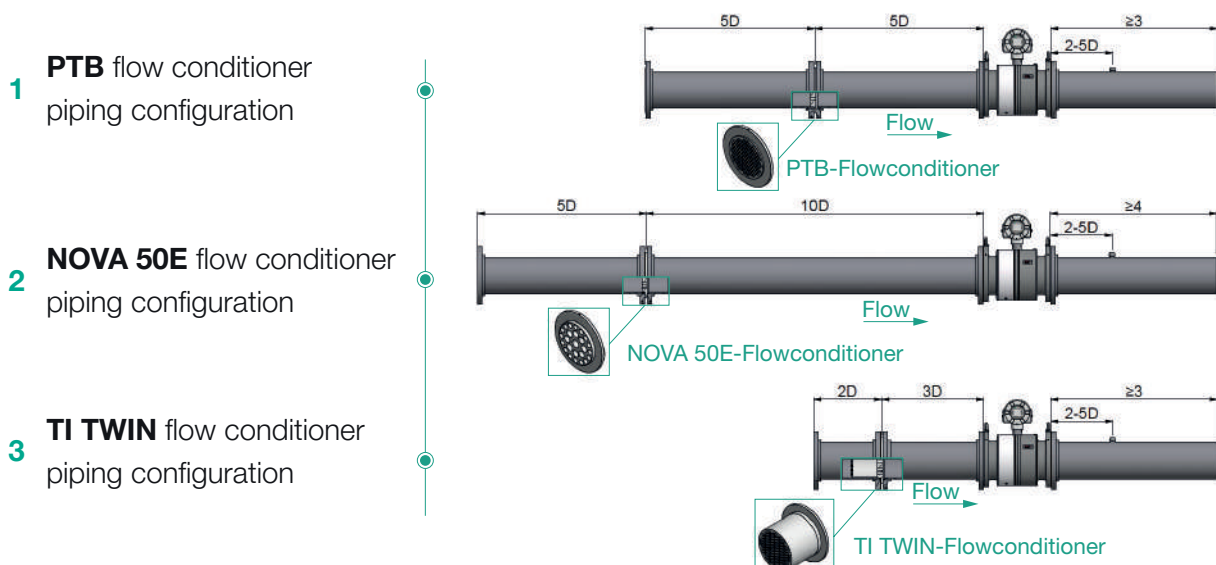



# Accessories

## For the electronic:

- Extended I/O board
- PT board

## For the meter:

- Transducers Extraction Tool
- Flow straightener

# Flow Conditioner

**FioSonic** flow-conditioner is selected according to target accuracy, piping configuration constrains and certification required between the below 3 models. It is mandatory for Custody Transfer measurements, while can be avoided for technical measurements (non custody transfer)



Flowconditioner-**PTB**



Flowconditioner-**NOVA 50-E**

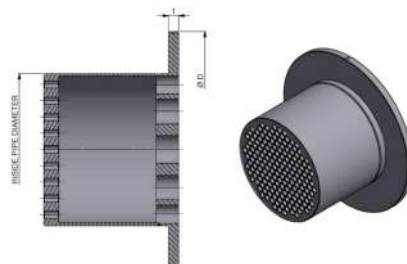

Flowconditioner-**TI TWIN**

**Figure 12** FioSonic flow conditioner

# Transducers extraction tool

The **FioSonic** transducer maintenance can be performed while gas is flowing in the pipeline using a suitable extraction tool (available for sizes  $\geq 8''$  (DN200)).

The extraction tool (available for sizes  $\geq 8''$  (DN200)) makes possible to remove FioSonic transducers for maintenance or replacement while the meter is flowing with gas.

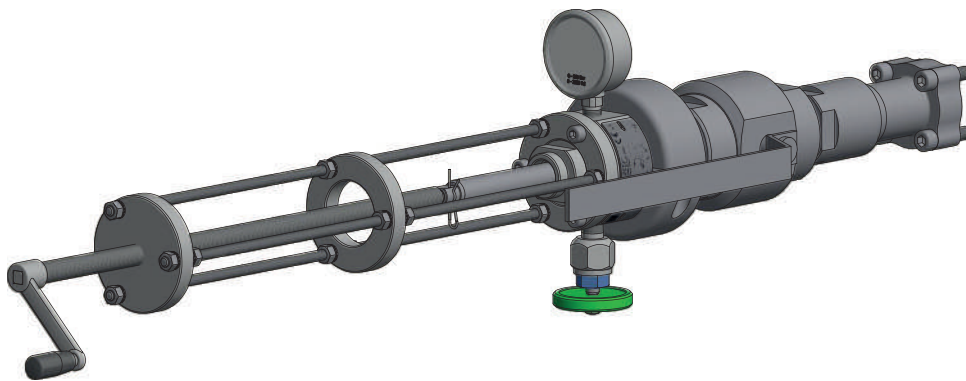
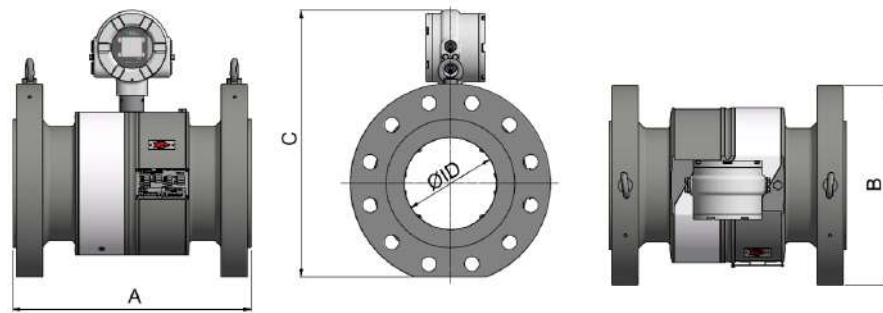

**Figure 13** FioSonic extraction tool



# Weights and Dimensions

## FioSonic



**Figure 14** FioSonic dimensions

Below table shows the minimum standard FioSonic dimensions for all FioSonic models (4P-3P or BX).

Different dimensions (i.e. face to face length of 3D) can be customized according to customer's need.

## Nominal size table

ØID Nominal Size inches   DN	Rating [ANSI]   PN	A-Length [mm]   inches	B-Width [mm]   inches	C-Height [mm]   inches	Weight [Kg]   lbs
3"   DN80	150   16	300   11.81	190   7.48	385   15.16	55   121
	300   50	350   13.78	210   8.27	396   15.59	60   132
	600   100	350   13.78	210   8.27	396   15.59	65   75
	900   150	400   17.75	240   9.45	408   16.06	75   165
4"   DN100	150   16	350   13.78	230   9.06	416   16.38	70   154
	300   50	350   13.78	255   10.04	425   16.73	80   176
	600   100	400   15.75	275   10.83	435   17.13	90   198
	900   150	450   17.72	290   11.42	447   17.60	100   220
6"   DN150	150   16	350   13.78	280   11.02	465   18.31	88   194
	300   50	400   15.75	320   12.60	485   19.09	106   234
	600   100	400   15.75	355   13.98	500   19.69	130   287
	900   150	450   17.72	380   14.96	515   20.28	150   331

**NOMINAL SIZE TABLE**

ØID Nominal Size inches   [DN]	Rating [ANSI]   PN	A-Length [mm]   inches	B-Width [mm]   inches	C-Height [mm]   inches	Weight [Kg]   lbs
8"   DN200	150   16	400   15.75	345   13.58	522   20.55	130   287
	300   50	500   19.69	380   14.96	545   21.46	160   353
	600   100	500   19.69	420   16.54	560   22.05	195   430
	900   150	500   19.69	470   18.50	588   23.15	235   518
10" / DN250	150   16	450   17.72	405   15.94	588   23.15	184   406
	300   50	550   21.65	445   17.52	606   23.86	220   485
	600   100	550   21.65	510   20.08	633   24.92	295   650
	900   150	550   21.65	545   21.46	656   25.83	335   739
12"   DN300	150   16	500   19.69	485   19.09	546   21.50	245   540
	300   50	600   23.62	520   20.47	666   26.22	305   672
	600   100	600   23.62	560   22.05	688   27.09	393   866
	900   150	600   23.62	610   24.02	713   28.07	440   940
14"   DN350	150   16	600   23.62	745   29.33	950   37.40	505   1113
	300   50	650   25.59	535   21.06	775   30.51	565   1246
	600   100	650   25.59	585   23.03	775   30.51	615   1356
	900   150	700   27.52	605   23.82	815   32.09	705   15.54
16"   DN400	150   16	600   23.62	595   23.43	840   37.07	640   1411
	300   50	700   27.56	650   25.59	840   37.07	715   1576
	600   100	700   27.56	685   26.97	870   34.25	805   1775
	900   150	750   29.53	705   27.76	870   34.25	880   1940
18"   DN450	150   16	700   27.56	635   25.00	900   35.43	760   1676
	300   50	750   29.53	710   27.95	900   35.43	875   1929
	600   100	900   35.43	745   29.33	950   37.40	1035   2282
	900   150	900   35.43	785   30.91	950   37.40	1150   2535
20"   DN500	150   16	750   29.53	700   27.56	970   38.19	950   2094
	300   50	800   31.10	775   30.51	970   38.19	1085   2392
	600   100	1000   39.37	815   32.09	1005   39.57	1315   2899
	900   150	1000   39.37	855   33.66	1005   39.57	1460   3219
24"   DN600	150   16	850   33.46	815   32.09	1090   42.91	1280   2822
	300   50	900   35.43	915   36.02	1090   42.91	1500   3307
	600   100	1100   43.31	940   37.01	1115   43.90	1800   3968
	900   150	1100   43.31	1040   40.94	1150   45.28	2260   4982
30"   DN750	150   16	1100   43.31	985   38.78	1250   49.21	2450   5401
	300   50	1150   45.28	1090   42.91	1250   49.21	2790   6151
	600   100	1300   51.18	1130   44.49	1270   50.00	3220   70.99
	900   150	1400   55.12	1230   48.43	1310   51.57	4150   9149



# Pietro Fiorentini

**TB0052ENG**



The data are not binding. We reserve the right  
to make changes without prior notice.

FioSonic\_technicalbrochure\_ENG\_revB

[www.fiorentini.com](http://www.fiorentini.com)