

IM-RM

Rotary meter



Revision C - Edition 09/2023



**USE, MAINTENANCE
AND WARNING
MANUAL**

1 - INTRODUCTION

FOREWORD

All rights reserved. No part of this publication may be reproduced, distributed, translated into other languages or transmitted by any electronic or mechanical media, including photocopies, recording or any other storage and retrieval system, for any other purposes that are not exclusively the personal use of the buyer, without the express written permission of the Manufacturer.

The manufacturer is in no way responsible for the consequences of operations carried out in a manner not in accordance with the manual.

GENERAL REMARKS

All the operating, maintenance instructions and recommendations described in this manual must be adhered to in order to:

- obtain the best possible performance from the equipment;
- keep the equipment in efficient conditions.

Training the personnel in charge is essential in order to:

- use and service the equipment properly;
- correctly apply the safety alerts and procedures recommended.

Revision: C

1.1 - REVISION HISTORY

Revision index	Date	Revision contents
A	01/2023	First issue
B	07/2023	<ul style="list-style-type: none">• Updated product images• Updated low-frequency (LF) sensor pulse output data
C	09/2023	Updated Maximum working pressure and Operating temperature range (Tab. 4.17).

Tab. 1.1.

INDEX

1 - INTRODUCTION	3
1.1 - REVISION HISTORY.....	5
2 - GENERAL INFORMATION	11
2.1 - MANUFACTURER IDENTIFICATION	11
2.2 - IDENTIFICATION OF THE PRODUCT	11
2.3 - REGULATORY FRAMEWORK.....	11
2.4 - WARRANTY	12
2.5 - ADDRESSEES, SUPPLY AND STORAGE OF THE INSTRUCTION MANUAL	12
2.6 - LANGUAGE	12
2.7 - SYMBOLS USED IN THE MANUAL.....	13
2.8 - APPLIED RATING PLATES	14
2.8.1 - GLOSSARY FOR NAMEPLATES	15
2.9 - GLOSSARY OF MEASUREMENT UNITS.....	16
2.10 - QUALIFIED PROFESSIONAL FIGURES.....	17
3 - SAFETY	19
3.1 - GENERAL SAFETY WARNINGS.....	19
3.2 - PERSONAL PROTECTIVE EQUIPMENT.....	20
3.3 - OBLIGATIONS AND PROHIBITIONS	21
3.4 - RESIDUAL RISKS	21
3.4.1 - RISKS DUE TO PRESSURE	22
3.4.2 - RISKS DUE TO EXPLOSIVE ATMOSPHERES	24
3.4.3 - EXPLOSION RISK	25
3.5 - SAFETY PICTOGRAMS	26
3.6 - RISK LEVEL	26

4 - DESCRIPTION AND OPERATION 27

4.1 - GENERAL DESCRIPTION AND OPERATION	27
4.1.1 - TOTALISER GROUP.....	28
4.1.2 - METROLOGICAL SEALS	29
4.2 - INTENDED USE	31
4.2.1 - ENVISAGED USE	31
4.2.2 - REASONABLY FORESEEABLE MISUSE	31
4.3 - POSSIBLE CONFIGURATIONS	32
4.3.1 - HTR VERSION	32
4.3.2 - TWIN VERSION.....	33
4.4 - TECHNICAL FEATURES/PERFORMANCE	34
4.4.1 - MODEL CAPACITIES AVAILABLE.....	35

5 - TRANSPORT AND HANDLING 37

5.1 - SPECIFIC WARNINGS FOR TRANSPORT AND HANDLING	37
5.2 - PACKAGING AND FASTENERS USED FOR TRANSPORT	38
5.2.1 - PACKAGING CONTENT.....	39
5.3 - PHYSICAL CHARACTERISTICS OF THE EQUIPMENT	40
5.4 - EQUIPMENT ANCHORING AND LIFTING METHOD.....	42
5.4.1 - HANDLING WITH FORKLIFT TRUCK	43
5.4.2 - CRANE HANDLING.....	45
5.5 - PACKAGING REMOVAL.....	46
5.5.1 - PACKAGING DISPOSAL	47
5.6 - STORAGE AND ENVIRONMENTAL CONDITIONS	48
5.6.1 - STORAGE LASTING LONGER THAN THE MAXIMUM TIME ALLOWED	48

6 - INSTALLATION	49
6.1 - SPECIFIC SAFETY WARNINGS	49
6.2 - INSTALLATION PRE-REQUISITES.....	50
6.2.1 - ALLOWED ENVIRONMENTAL CONDITIONS.....	50
6.2.2 - STORAGE LASTING LONGER THAN THE MAXIMUM TIME ALLOWED	50
6.2.3 - CHECKS BEFORE INSTALLATION	51
6.3 - GENERAL INFORMATION ON THE LINE	53
6.3.1 - MOUNTING POSITION AND FLOW DIRECTION	53
6.4 - INSTALLATION PROCEDURES	55
6.4.1 - EQUIPMENT INSTALLATION.....	55
6.4.1.1 - TIGHTENING TORQUES	56
6.4.2 - ELECTRICAL CONNECTIONS	57
6.4.2.1 - LOW-FREQUENCY SENSOR IMPULSE OUTPUT (LF).....	58
6.4.2.2 - HIGH-FREQUENCY (HF) SENSOR IMPULSE OUTPUT.....	59
6.5 - POST-INSTALLATION INSTRUCTIONS	60
6.6 - LUBRICATION.....	60
6.6.1 - FILLING THE OIL TANKS.....	61
7 - COMMISSIONING/MAINTENANCE EQUIPMENT.....	63
7.1 - LIST OF EQUIPMENT.....	63
8 - COMMISSIONING	65
8.1 - GENERAL WARNINGS	65
8.1.1 - SAFETY REQUIREMENTS FOR COMMISSIONING	65
8.2 - PRELIMINARY PROCEDURES FOR COMMISSIONING	66
8.3 - METER COMMISSIONING	67
9 - MAINTENANCE AND FUNCTIONAL CHECKS.....	69
9.1 - GENERAL WARNINGS	69
9.2 - MAINTENANCE OPERATIONS.....	70
9.2.1 - OPERATIONS PRIOR TO MAINTENANCE.....	70
9.3 - ROUTINE MAINTENANCE	71
9.3.1 - PERIODICALLY CHECKING AND INSPECTING THE EQUIPMENT FOR PROPER OPERATION	71
9.3.2 - TOPPING UP OIL.....	72
9.3.3 - OIL CHANGE	73
9.4 - SPECIAL MAINTENANCE	75
9.4.1 - UNINSTALLING THE METER.....	76

10 - TROUBLESHOOTING..... 77

10.1 -GENERAL WARNINGS	77
10.2 -OPERATOR QUALIFICATION SPECIFICATION	78
10.3 -TROUBLESHOOTING	78
10.4 -TROUBLESHOOTING TABLES	79

11 - UNINSTALLATION AND DISPOSAL 81

11.1 -GENERAL SAFETY WARNINGS.....	81
11.2 -QUALIFICATION OF THE OPERATORS IN CHARGE.....	81
11.3 -UNINSTALLATION.....	81
11.4 -INFORMATION REQUIRED IN CASE OF RE-INSTALLATION.....	82
11.5 -DISPOSAL INFORMATION.....	82
11.5.1 -EQUIPMENT MATERIALS.....	83

12 - RECOMMENDED SPARE PARTS 85

12.1 -GENERAL WARNINGS	85
12.2 -HOW TO REQUEST SPARE PARTS.....	85
12.3 -SPARE PARTS LIST	85

PAGE INTENTIONALLY LEFT BLANK

2 - GENERAL INFORMATION

2.1 - MANUFACTURER IDENTIFICATION

Manufacturer	PIETRO FIORENTINI S.P.A.
Address	Via Enrico Fermi, 8/10 36057 Arcugnano (VI) - ITALY Tel. +39 0444 968511 Fax +39 0444 960468 www.fiorentini.com sales@fiorentini.com

Tab. 2.2.

NOTICE!

For any problems with the equipment, please contact PIETRO FIORENTINI S.p.A.

2.2 - IDENTIFICATION OF THE PRODUCT

Equipment	ROTARY METER	
Series	IM-RM	
Available models	<ul style="list-style-type: none"> • G10 • G16 • G25 • G40 • G65 • G100 • G100-Twin 	<ul style="list-style-type: none"> • G160 • G160-Twin • G250 • G250-Twin • G400-Twin • G650-Twin
Versions	<ul style="list-style-type: none"> • HTR 	<ul style="list-style-type: none"> • Twin

Tab. 2.3.

2.3 - REGULATORY FRAMEWORK

PIETRO FIORENTINI S.P.A. with registered office in Arcugnano (Italy) - Via E. Fermi, 8/10, declares that the equipment in the IM-RM series covered by this manual is designed, manufactured, tested and controlled as far as applicable in accordance with:

- the requirements of the Directives:
 - 2014/32/EU “MID”;
 - 2014/34/EU “ATEX”;
 - 2014/68/UE “PED”;
- the requirements of the standards:
 - EN 12480: 2002;
- OIML Recommendations R137 1&2 :2012.

NOTICE!

Please contact the manufacturer for specific approvals.

NOTICE!

The EU Declaration of Conformity is delivered together with the equipment and this manual.

2.4 - WARRANTY

PIETRO FIORENTINI S.P.A. guarantees that the equipment was manufactured using the best materials, with high quality workmanship, and complies with the quality requirements, specifications and performance set out in the order. The warranty shall be considered null and void and PIETRO FIORENTINI S.P.A. shall not be liable for any damage and/or malfunctions:

- due to any acts or omissions of the purchaser or end-user, or any of their carriers, employees, agents, or any third party or entity;
- in the event that the purchaser, or a third party, makes changes to the equipment supplied by PIETRO FIORENTINI S.P.A. without the prior written approval of the latter;
- in the event of failure by the purchaser to comply with the instructions contained in this manual, as provided by PIETRO FIORENTINI S.P.A.

NOTICE!

The warranty conditions are specified in the commercial contract.

2.5 - ADDRESSEES, SUPPLY AND STORAGE OF THE INSTRUCTION MANUAL

The instruction manual is intended for qualified technicians responsible for operating and managing the equipment throughout its service life.

It contains the necessary information to properly use the equipment and keep its functional and qualitative characteristics unchanged over time. All information and warnings for safe, correct use are also provided.

The manual, as well as the declaration of conformity and/or test certificate, is an integral part of the equipment and must always accompany it whenever it is moved or resold. It is the responsibility of the qualified professionals (see paragraph 2.10) to use and manage the equipment.

NOTICE!

The meter illustrations in this manual refer to standard models. PIETRO FIORENTINI S.p.A.:

- reserves the right to change the contents of this manual at any time and without notice;
- disclaims any liability arising from operations not described in this manual.

WARNING!

Removing, rewriting or modifying the pages of the manual and their contents is not allowed. PIETRO FIORENTINI S.p.A. shall not be held liable for any damage to people, animals and property caused by failure to adhere to the warnings and operating procedures described in this manual.

2.6 - LANGUAGE

The original instruction manual was drawn up in Italian.

Any translations into additional languages are to be made from the original instruction manual.

HAZARD!

The translations into other languages cannot be fully verified. If any inconsistency is found, please refer to the original instruction manual.





If inconsistencies are found or the text does not make sense:

- stop any actions;
- immediately contact PIETRO FIORENTINI S.p.A. at the addresses specified in paragraph 2.1 (“Identification of the manufacturer”).

WARNING!

PIETRO FIORENTINI S.p.A. shall be held liable for the information provided in the original manual only.

2.7 - SYMBOLS USED IN THE MANUAL

Symbol	Definition
	Symbol used to identify important warnings for the safety of the operator and/or equipment.
	Symbol used to identify an ELECTRICAL HAZARD.
	Symbol used to identify DANGERS GENERATED BY STATIC ELECTRICITY.
	Symbol used to identify information of particular importance in the instruction manual. The information may also concern the safety of the personnel involved in using the equipment.
	Obligation to consult the instruction manual/booklet. Indicates a requirement for the personnel to refer to (and understand) the operating and warning instructions of the machine before working with or on it.

Tab. 2.4.

HAZARD!

Alerts to a hazard with a high level of risk, an imminent hazardous situation which, if not prevented, will result in death or severe damage.

WARNING!

Alerts to a hazard with a medium level of risk, a potentially hazardous situation which, if not prevented, may result in death or severe damage.

ATTENTION!

Alerts to a hazard with a low level of risk, a potentially hazardous situation which, if not prevented, could result in minor or moderate damage.

NOTICE!

Alerts to specific warnings, directions or notes of particular concern, that are not related to physical injury, as well as practices for which physical injury is not likely to occur.

2.8 - APPLIED RATING PLATES

WARNING!

Removing nameplates and/or replacing them with other plates is strictly not allowed.
Should the plates be unintentionally damaged or removed, the customer must notify
PIETRO FIORENTINI S.p.A.

The equipment is equipped with identification plates.

The rating plate contains the identification details of the equipment and its accessories to be cited in case of need to PIETRO FIORENTINI S.p.A.

The example of the rating plate applied to the meter is shown in Tab.2.5:

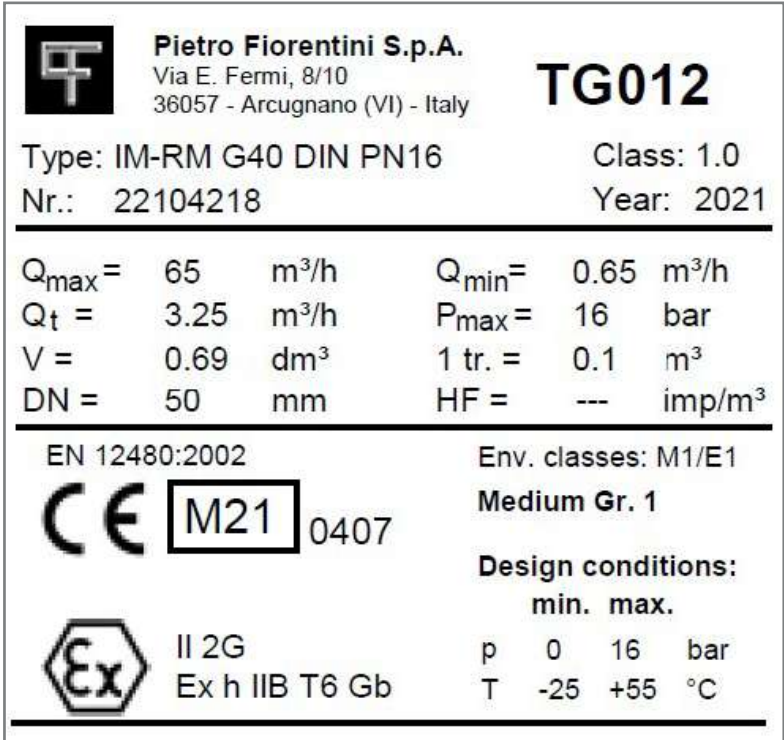
Id.	Type	Image
1	IDENTIFICATION PLATE WITH CE MARKING	

Tab. 2.5.

2.8.1 - GLOSSARY FOR NAMEPLATES

The terms and abbreviations used on nameplates are described in Tab. 2.6.:

Term	Description
TG012	EU Type Examination Certificate Number (MID Directive).
Type	Complete name of the meter.
Class	Accuracy class.
No.	Meter serial number.
Year	Year of manufacture.
Q_{max}	Maximum capacity.
Q_{min}	Minimum flow rate.
Q_t	Transition flow rate.
P_{max}	Maximum allowable pressure.
V	Cyclic meter volume.
1 tr.	One rotation.
DN	Nominal diameter.
HF	Number of pulses / m ³ high-frequency output (if any).
EN12480	European standard for rotary gas meters.
Env. Classes	Environmental classes.
Medium Gr. 1	Equipment suitable for use with group 1 hazardous gases (according to PED Directive 2014/68/EU).
CE	CE marking ensuring the conformity of the product with the requirements of the applicable EU directives or regulations.
M21	Additional metrology marking in accordance with Directive 2014/32/EU.
0407	Number of the Notified Body involved in the production control phase.
EX	Specific marking of explosion protection.
p	Pressure range (bar).
T	Temperature range (°C).

Tab. 2.6.

2.9 - GLOSSARY OF MEASUREMENT UNITS

Type of measurement	Unit of measurement	Description
Volumetric flow rate	Sm ³ /h	Standard cubic metres per hour
	Sm ³	Standard cubic metres
	m ³ /h	Cubic metres per hour
	m ³	Cubic metres
Pressure	bar	Unit of measurement in the CGS system
	"wc	Water column inch
	Pa	Pascal
Temperature	°C	Degree centigrade
	°F	Fahrenheit degree
	K	Kelvin
Tightening torque	Nm	Newton metro
Sound pressure	dB	Decibel
Other measures	V	Volt
	W	Watt
	F	Farad
	H	Henry
	A	Ampere
	Ω	Ohm

Tab. 2.7.

2.10 - QUALIFIED PROFESSIONAL FIGURES

Qualified operators in charge of using and managing the equipment throughout its technical service life:

Professional figure	Definition
Mechanical maintenance technician	<p>Qualified technician able to:</p> <ul style="list-style-type: none"> perform preventive/corrective maintenance operations on all mechanical parts of the equipment subject to maintenance or repair; access all device parts for visual inspection, equipment checks, adjustments and calibrations. <p>The maintenance mechanical technician is not authorised to operate on live electrical systems (if any).</p>
Electrical maintenance technician	<p>Qualified technician able to:</p> <ul style="list-style-type: none"> perform preventive/corrective maintenance operations on all electrical parts of the device subject to maintenance or repair; read wiring diagrams and check the correct functional cycle; perform adjustments and operate on electrical systems for maintenance, repair and replacement of worn parts. <p>The electrical maintenance technician can operate in the presence of voltage inside electrical panels, junction boxes, control equipment etc. only if he/she is deemed to be suitable (S.P.).</p> <p>For general requirements, refer to the IEC EN 50110-1:2014 standard.</p>
Worker in charge of transport, handling, unloading and placement on site	<p>Operator qualified to:</p> <ul style="list-style-type: none"> use lifting equipment; handle materials and equipment. <p>The equipment must be lifted and handled strictly in accordance with the instructions provided by the manufacturer as well as the regulations in force at the place where the equipment is installed.</p>
Installer	<p>Qualified operator able to:</p> <ul style="list-style-type: none"> carry out all the operations necessary to properly install the equipment; perform all the operations necessary for the proper functioning of the equipment and the system in safety.
User's technician	<p>Technician trained and authorized to use and manage the equipment for the activities for which it was supplied. They must:</p> <ul style="list-style-type: none"> be able to perform all operations required to properly run the equipment and the system, ensuring their own safety and that of any personnel on site; have proven experience in properly using the equipment similar to that described in this instruction manual, and be trained, informed and instructed in this regard. <p>The technician may carry out maintenance only if authorised/qualified to do so.</p>

Tab. 2.8.

PAGE INTENTIONALLY LEFT BLANK

3 - SAFETY

3.1 - GENERAL SAFETY WARNINGS

WARNING!

The equipment described in this instruction manual is:

- a device subjected to pressure in pressurised systems;
- normally installed in systems carrying flammable gases (for example: natural gas).

WARNING!

If the gas used is a combustible gas, the installation area of the equipment is defined as a “danger zone” as there are residual risks that potentially explosive atmospheres may be generated.

In “danger zones” and in close proximity thereto:

- there must not be any effective sources of ignition;
- Smoking and open flames are prohibited.

WARNING!

Never disassemble the equipment in the presence of pressure.

WARNING!

- It is strictly forbidden to repair or make any modifications to the equipment.
- For information and warnings concerning the maintenance of the equipment, please refer to Chapter 9 of this manual.

ATTENTION!

Authorised operators must not carry out operations or services on their own initiative that do not fall within their competence.

Never operate the equipment:

- while under the influence of intoxicating substances such as alcohol;
- if you are using drugs that may slow reaction times.

NOTICE!

The employer must train and inform operators:

- on how to behave during operations;
- on the equipment to be used.

Before installation, commissioning or maintenance, operators must:









- take note of the safety regulations applicable to the place of installation they are working in;
- obtain the necessary permits to operate when required;
- wear the personal protective equipment required by the procedures described in this instruction manual;
- ensure that the required collective protective equipment and safety information are available in the area they are operating in.

3.2 - PERSONAL PROTECTIVE EQUIPMENT

The following table shows the Personal Protective Equipment (PPE) and its description; an obligation is associated with each symbol.

Personal protective equipment means any equipment intended to be worn by the worker in order to protect them against one or several risks that are likely to threaten their safety or health during work.

For the operators in charge, depending on the type of work requested, the most appropriate PPE from those reported in Tab.3.9 must be used:

Symbol	Meaning
	Obligation to use safety or insulated gloves. Indicates a requirement for the personnel to use safety or insulated gloves.
	Obligation to use safety goggles. Indicates a requirement for personnel to use protective goggles for eye protection.
	Obligation to use safety shoes. Indicates a requirement for the personnel to use accident-prevention safety shoes.
	Obligation to use noise protection equipment. Indicates a requirement for the personnel to use ear muffs or ear plugs to protect their hearing.
	Obligation to wear protective clothing. Indicates a requirement for the personnel to wear specific protective clothing.
	Obligation to use a protective mask. Indicates a requirement for the personnel to use respiratory masks in the event of a chemical risk.
	Obligation to use a protective helmet. Indicates a requirement for the personnel to use protective helmets.
	Obligation to wear high visibility vests. Indicates a requirement for the personnel to use high visibility vests.

Tab. 3.9.

WARNING!

Each licensed operator is obliged to:

- **take care of his/her own health and safety and that of other people in the workplace who are affected by his/her actions or omissions, in accordance with the training, instructions and equipment provided by the employer;**
- **appropriately use the PPE made available;**
- **immediately report to the employer, the manager or the person in charge of the deficiencies of the means and devices as well as any possible dangerous conditions of which they become aware.**

3.3 - OBLIGATIONS AND PROHIBITIONS

The following is a list of obligations and prohibitions to be observed for the safety of the operator:

It is mandatory to:

- carefully read and understand the use, maintenance and warning manual;
- check whether the downstream equipment is suitably sized according to the performance required of the meter in the actual operating condition;
- before installing the equipment, strictly refer to the details specified on the nameplates and in the manual;
- avoid knocks and violent impacts that could damage the equipment.

It is forbidden to:

- operate in various capacities on the equipment without the PPE indicated in the work procedures described in this manual;
- operate in the presence of open flames or bring open flames close to the work area;
- smoke near the equipment or while working on it;
- use the equipment with parameters other than those indicated on the nameplate;
- use the equipment with fluids other than those indicated in this manual;
- use the equipment outside the operating temperature range specified in this manual;
- carry out maintenance with the equipment in operation or under pressure;
- install or use the equipment in environments other than those specified in this manual.

3.4 - RESIDUAL RISKS

NOTICE!

The equipment is suitable for the hazardous area 'Zone 1' for the presence of gas (ATEX marking II 2G).

WARNING!

If there are any functional faults, do not operate.

Immediately contact PIETRO FIORENTINI S.p.A. for the necessary directions.

3.4.1 - RISKS DUE TO PRESSURE

 **WARNING!**

The IM-RM meters:

- are supplied as components to be installed in the end customer's gas system;
- must not be installed where the line pressure may exceed PS.

It is the end customer's responsibility to ensure compliance with the requirements of the directives mentioned in this section.

In accordance with the requirements of PED Directive 2014/68/EU point 1.2 of Annex I, below is an assessment of the risks associated with the equipment and an indication of the principles adopted for their prevention, according to the following classification:

Ref. "PED" Directive Annex I	Essential safety requirements	Instructions
2.3	<p>Provisions to ensure safe handling and operation.</p> <p>The method of operation specified for pressure equipment must be such as to preclude any reasonably foreseeable risk in operation of the equipment.</p> <p>Particular attention must be paid, where appropriate, to:</p>	-
	<ul style="list-style-type: none"> • to closing and opening devices. 	<p>When removing and replacing any parts (such as oil plugs, level gauges, HF sensors or thermowells), the end customer must ensure that:</p> <ul style="list-style-type: none"> • the IM-RM meter was correctly isolated; • the gas pressure has been safely discharged.
	<ul style="list-style-type: none"> • dangerous discharge of pressure relief valve. 	<p>The meter IM-RM is not equipped with pressure relief valves. Pressure relief valves must be provided on the gas system of the end customer.</p>
	<ul style="list-style-type: none"> • devices to prevent physical access in the presence of pressure or vacuum. 	<p>The end customer must ensure that the IM-RM meter is installed in a system:</p> <ul style="list-style-type: none"> • appropriately designed; • with the possibility of restricting access.
	<ul style="list-style-type: none"> • within the temperature range. 	<p>It is the responsibility of the end customer to assess the expected service surface temperature and, if necessary, to take the necessary precautions.</p> <div style="border: 1px solid blue; padding: 5px;">  NOTICE! The temperature range is indicated on the rating plate. </div>
	<ul style="list-style-type: none"> • decomposition of unstable fluids. 	<p>The IM-RM meter is not supposed to come into contact with unstable fluids, in any case the end user must:</p> <ul style="list-style-type: none"> • assess the risk; • take all measures deemed necessary.

Ref. "PED" Directive Annex I	Essential safety requirements	Instructions
2.4	<p>Means of inspection. The design and manufacturing of the pressure equipment must ensure that all the necessary inspections to ensure its safety can be carried out.</p>	<p>For the inspection of all pressure parts, the IM-RM meter must be removed from the line. It is the responsibility of the end customer to:</p> <ul style="list-style-type: none"> ensure that the internal pressure has been safely discharged before the meter is removed from the line; use appropriate tools; ensure that removal personnel are trained in the assembly and disassembly of high-pressure gas lines and related equipment.
2.5	<p>Means of draining and venting. Where necessary, adequate equipment must be provided for discharging and venting pressure equipment.</p>	<p>The IM-RM meter is not equipped with means of discharge or venting internal pressure. It is the end customer's responsibility to ensure that the equipment is installed in a piping system equipped with venting devices that allow for safe pressure relief.</p>
2.6	<p>Corrosion and other chemical attacks.</p>	<p>The process fluid for which the IM-RM meter is designed is not considered to cause serious corrosion problems. It is the responsibility of the end customer to verify any changes in the fluid. External corrosion is not considered / allowed.</p>
2.7	<p>Wear.</p>	<p>It is not believed that the use of the IM-RM gas meter will cause any anomalies due to wear and tear. It is the responsibility of the end customer to:</p> <ul style="list-style-type: none"> install suitable filters upstream of the meter; ensure that no moisture is present.
2.8	<p>Assemblies.</p>	<p>The IM-RM meter is delivered fully assembled.</p>
2.9	<p>Provisions for filling and discharge.</p>	<p>Pressurise the IM-RM meter carefully while maintaining a pressure gradient of no more than 35 kPa /s (0.35 bar/s).</p>
2.10	<p>Protection against exceeding the allowable limits of pressure equipment.</p>	<p>The IM-RM meter has no integrated pressure limiting devices. It is the responsibility of the end customer to ensure that:</p> <ul style="list-style-type: none"> the IM-RM meter is installed within a gas system with adequate protection against overpressure (e.g. PSV pressure relief valves); temporary pressure peaks are in any case less than 10% of the maximum operating pressure.
2.12	<p>External fire.</p>	<p>The IM-RM meter has no specific accessories to limit the damage caused by a fire. It is the responsibility of the end customer to provide adequate fire-fighting facilities on site.</p>

Tab. 3.10.

3.4.2 - RISKS DUE TO EXPLOSIVE ATMOSPHERES

WARNING!

If the gas used is a combustible gas, the area where the equipment is installed is defined as a 'hazardous area' because there is a residual risk of potentially explosive atmospheres forming where effective ignition sources must be avoided.

NOTICE!

The PIETRO FIORENTINI S.p.A. meters are supplied as components to be installed in the end customer's gas system.
The end user is responsible for ensuring compliance with the requirements of the directive mentioned in this section.

Table 3.11. shows the conditions that can lead to the generation of potentially explosive atmospheres by meters of the IM-RM series according to the requirements of the ATEX Directive 2014/34/EU point 1.0.6:

Operating conditions	Essential safety requirements	Management measures included in the use, maintenance and warning manual	
Installation	During the equipment installation: <ul style="list-style-type: none"> outdoors; in a naturally ventilated environment. 	In the manual, the need for hazard area classification according to EN 60079-10-1 is indicated (by the end customer).	
	The installation room temperature must respect the range -25°C to +55°C	The manual indicates the need to respect the temperature range.	
	Intrinsically safe electrical connections.		The manual indicates the characteristics and reference parameters for electrical connections which must only be made on intrinsically safe circuits.
			LF and HF pulse generators are sealed by PIETRO FIORENTINI S.p.A. and cannot be opened or repaired.
			Intrinsically safe light curtains (Zener) must be installed outside areas classified as potentially explosive.
		The connections of LF and HF pulse generators must be made with appropriate connectors supplied by PIETRO FIORENTINI S.p.A..	
First start-up	Before commissioning, the external tightness of the portion of the system on which the equipment is installed must be tested at a suitable pressure.	The manual indicates the need to fulfil this requirement.	
Use in normal conditions	The installation is subject to surveillance according to; <ul style="list-style-type: none"> national rules in force; good practice; the equipment manufacturer's manual. 	The manual reports that periodic checks must be carried out during the life of the equipment.	
Maintenance	Any repair or maintenance work when the equipment is pressurised or in operation is prohibited.	The manual indicates the need to fulfil this requirement.	

Operating conditions	Essential safety requirements	Management measures included in the use, maintenance and warning manual
Decommissioning	<ul style="list-style-type: none"> The section of the plant in which the equipment is installed must be depressurised. The residual gas must be discharged safely. 	The manual indicates the need to fulfil this requirement.

Tab. 3.11.

3.4.3 - EXPLOSION RISK

The equipment is suitable for installation in hazardous areas in connection with explosive gas atmospheres "zone 1", i.e. areas in which an explosive atmosphere due to the presence of gas during normal operation may be present periodically or occasionally.

In these areas any sparks produced by electrostatic discharges, of electrical origin, of mechanical origin, hot surfaces, flames, stray electric currents, can produce explosions.

WARNING!

During the various operational phases (installation, configuration and maintenance) of the equipment, it is mandatory to implement electrostatic discharge protection measures.

NOTICE!

PIETRO FIORENTINI S.p.A. disclaims any liability resulting from the risks and consequences caused by non-compliance with these provisions.

The authorised operator must proceed as follows, during the various operational phases, to avoid the risk:

Operational phase	Obligations of the operator
Installation	<ul style="list-style-type: none"> Wear professional safety footwear with ESD characteristics; Wear work clothes that dissipate electrostatic charges; Use a damp cloth for cleaning.
Configuration	<ul style="list-style-type: none"> Wear professional safety footwear with ESD characteristics; Wear work clothes that dissipate electrostatic charges.
Maintenance	<ul style="list-style-type: none"> Wear professional safety footwear with ESD characteristics; Wear work clothes that dissipate electrostatic charges; Use a damp cloth for cleaning.

Tab. 3.12.

3.5 - SAFETY PICTOGRAMS

 **HAZARD!**

It is absolutely forbidden to remove any safety pictograms that may be on the equipment or packaging. The user is obliged to replace safety pictograms which, as a result of wear and tear, removal or tampering are illegible (contact PIETRO FIORENTINI S.p.A. for this).

3.6 - RISK LEVEL

Depending on the operating conditions, use and configuration required, the equipment may generate noise beyond the limits allowed by current legislation in the country of installation.

For the value of the noise generated by the equipment and further information, contact PIETRO FIORENTINI S.p.A.

 **ATTENTION!**

The obligation to use earmuffs or ear plugs to protect the hearing of qualified professional figures (reference paragraph 2.10) remains in the event that the noise in the installation environment of the equipment (depending on specific operating conditions) exceeds the value of 85 dBA.

4 - DESCRIPTION AND OPERATION

4.1 - GENERAL DESCRIPTION AND OPERATION

The equipment IM-RM is a rotary volumetric meter used for gas measurement applications.

The main function of the IM-RM equipment is to record the volume of gas passing through it.

The meter, thanks to two counter-rotating pistons, captures and transfers a precise volume of gas downstream with each rotation. The volume of gas transferred is proportional to the number of revolutions of the pistons.

A magnetic coupling transmits the motion of the pistons to the reading unit of the totaliser unit.

The main elements of the equipment are specified in Tab.4.13:

Pos.	Description	Pos.	Description
1	Body	6	Metrological seals
2	Totaliser group	7	Measuring cartridge
3	Oil filler cap	8	Cover
4	Oil level sight glass	9	Magnetic coupling
5	Oil drain plug	10	Thermowell

Tab. 4.13.

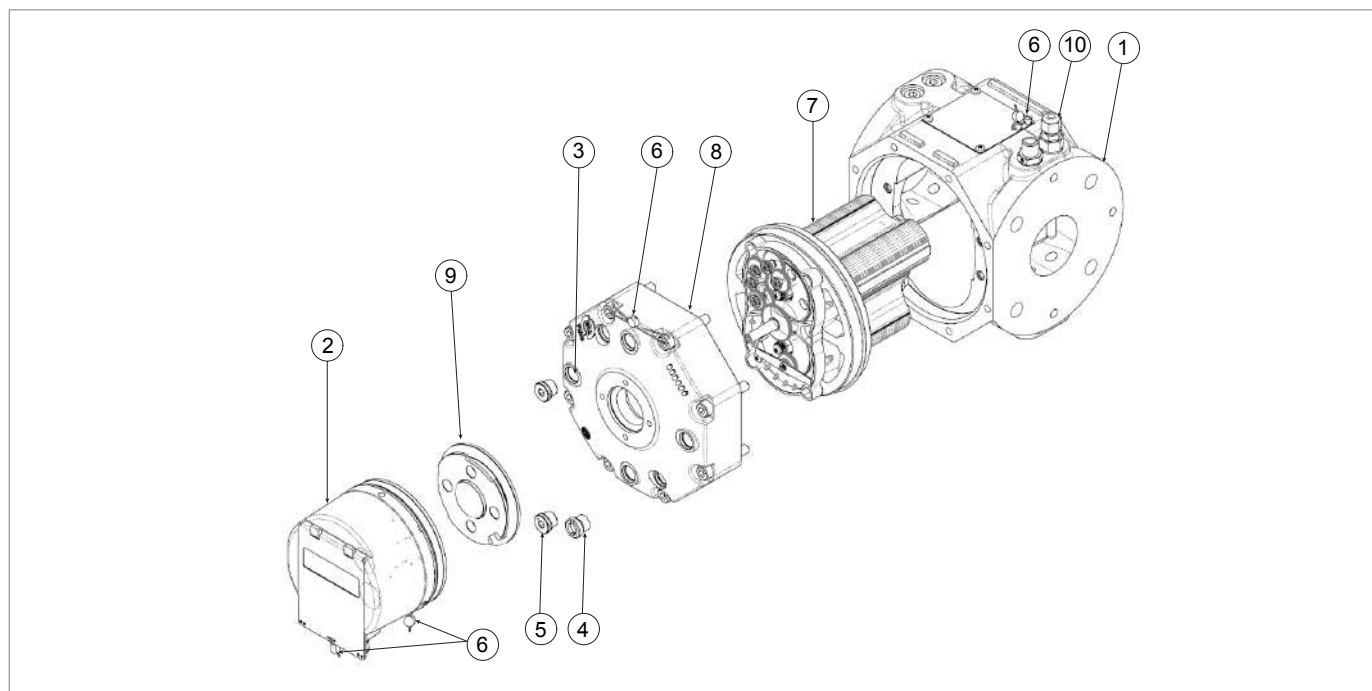

Fig. 4.1. General description IM-RM

4.1.1 - TOTALISER GROUP

The totaliser unit (A) is attached to the front of the IM-RM meter (B) via a hybrid connector with a magnetic coupling (C-D), which enables the transmission of motion between the pistons and the totaliser unit.

The totaliser unit (A) has an IP67 degree of protection.

Magnetic coupling allows:

- an adjustable orientation of 355°;
- removal/installation with just 'one turn and one click';
- the operation of the odometer on the mechanical indicator (E).

The gas quantity (expressed in m³), measured by the totaliser unit (A), is visible on the 8-digit mechanical indicator (E), which cannot be reset to one or two decimal places.

The totalising unit (A) is equipped with a low-frequency pulse generator device (LF) to which the seal (F) is applied.

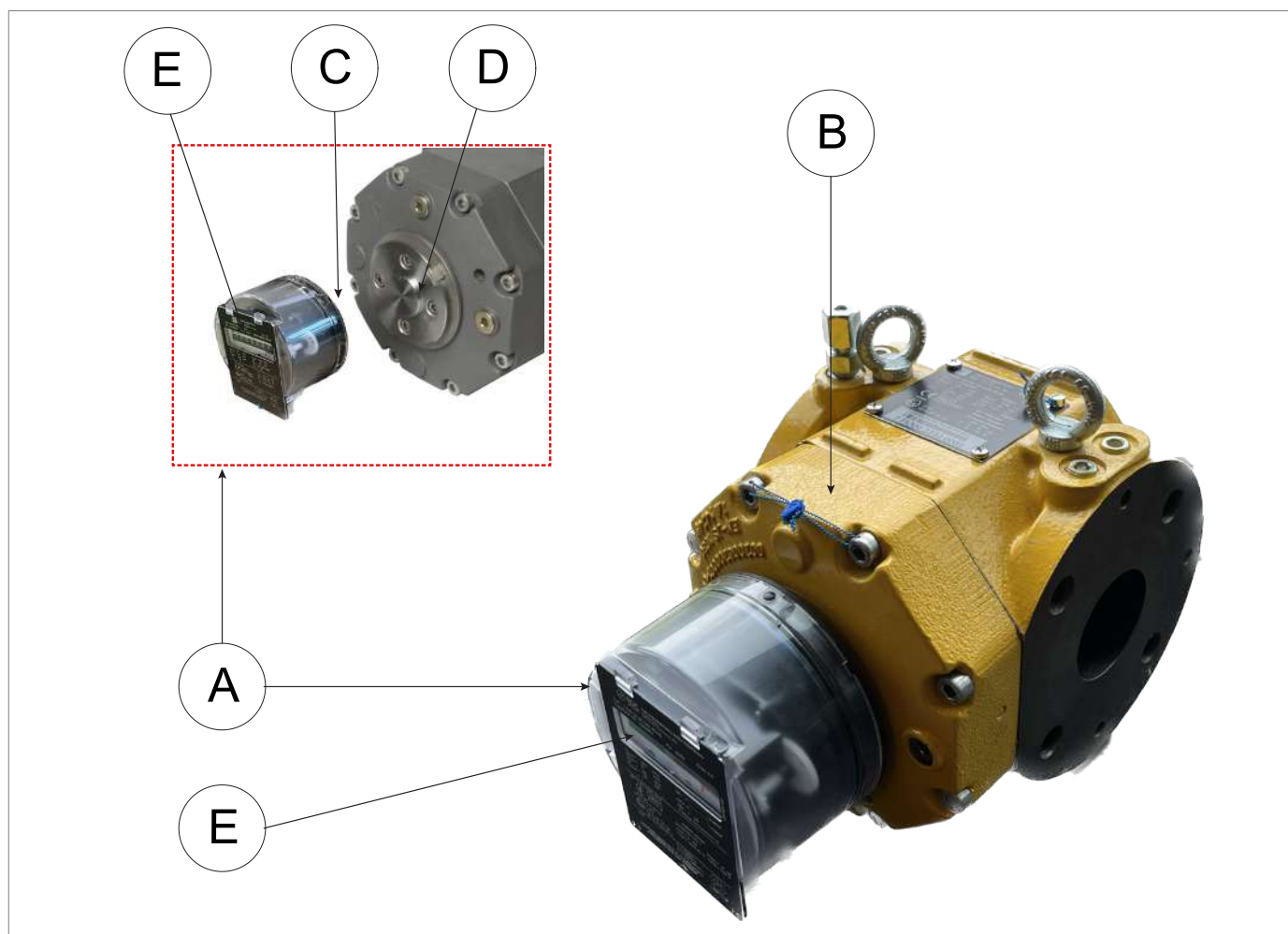

Fig. 4.2. Totaliser group

4.1.2 - METROLOGICAL SEALS

The IM-RM meter is fitted with metrological seals. Metrological seals are applied to the meter as in Table 4.14 and Table 4.15.

Any additional seals applied to the meter are not metrological.

! NOTICE!

Removing the metrological seals voids the calibration.

! NOTICE!

The following tables and figures are indicative and are intended only to show the position of the metrological seals.

Metrological seals on IM-RM 121 mm

Multi-position meter

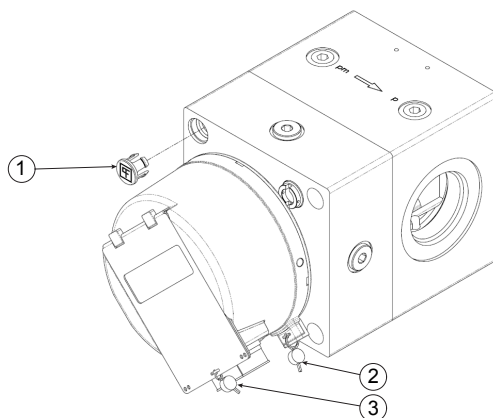

Pos.	Description
1	Closure of meter body.
2	Seal of the nameplate and impulse generator.
3	Seal of the totalising group.

Tab. 4.14.

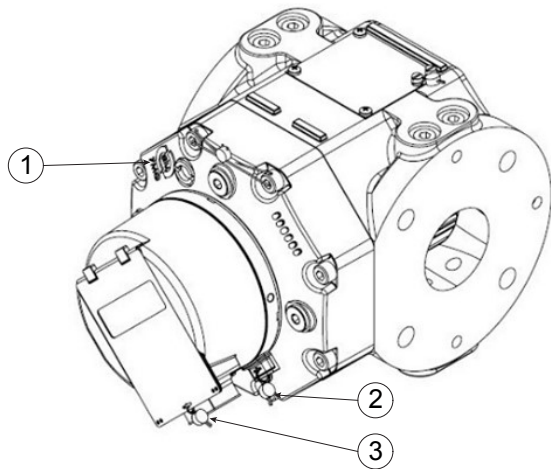
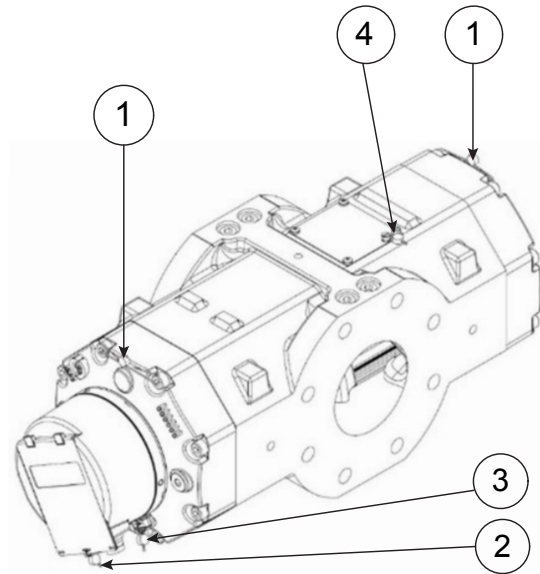
Metrological seals on IM-RM 171 ÷ 241 mm
Standard meter

Twin version meter

Pos.	Description
1	Closure of meter body.
2	Impulse generator closure and nameplate fixing (see notice).
3	Seal of the totalising group.
4	Seal the plate on the meter body (top and/or bottom).

NOTICE!

The meter plate can be:

- fixed on the body and protected with the seal in pos. 4;
- placed on the front of the totaliser unit and protected with the seal at Pos.2 (typical multi-position meter solution).

When the nameplate is attached to the totaliser unit, the nameplate on the body indicates the direction of gas flow.

Tab. 4.15.

4.2 - INTENDED USE

4.2.1 - ENVISAGED USE

The equipment in question is intended for:

Operation	Permitted	Unpermitted	Work environment
Measurement of the volume of:	Gaseous, non-aggressive or corrosive, dry and pre-filtered fluids: <ul style="list-style-type: none"> • natural gas; • argon; • butane; • ethane; • nitrogen; • carbon monoxide; • carbon dioxide; • air; • methane; • pentane; • propane. 	<ul style="list-style-type: none"> • Liquids. • Any other type of gas other than permitted. 	Installations for the transport and distribution of gaseous fluids permitted to supply networks for use: <ul style="list-style-type: none"> • residential (even at high flow rates); • commercial; • industrial use.

Tab. 4.16.

The equipment in question is designed to be used:

- only within the limits indicated on the nameplate;
- according to the instructions and limits of use given in this manual.

Safe work parameters are:

- use within the limits stated on the nameplate and in this manual;
- compliance with the procedures in the manual;
- routine maintenance to be carried out when and how recommended;
- special maintenance to be carried out if required;
- do not tamper with and/or bypass the safety devices.

4.2.2 - REASONABLY FORESEEABLE MISUSE

Incorrect and reasonably foreseeable use means the use of the equipment in a way not foreseen in the phase but which can derive from easily predictable human behaviour:

- use of the equipment other than as provided for in section 4.2.1 ("Intended use");
- use of the equipment with corrosive/aggressive fluids;
- use of the equipment with fluids that have not been properly treated upstream;
- use of the equipment with liquids;
- use of the equipment outside the prescribed limits;
- use of the equipment as a spacer when welding pipes;
- instinctive reaction of an operator in the event of a malfunction, accident or breakdown while using the equipment;
- behaviour resulting from pressure to keep the equipment running under all circumstances;
- behaviour resulting from carelessness;
- behaviour resulting from the use of the equipment by unauthorised and unsuitable people (children, disabled);
- use the equipment outside the prescribed limits;

Any use of the equipment other than the intended use must be previously approved in writing by PIETRO FIORENTINI S.p.A. If no written approval is provided, use shall be considered improper.

In the event of "improper use", PIETRO FIORENTINI S.p.A. shall not be held liable for any damage caused to people or property, and any type of warranty on the equipment shall be deemed void.

4.3 - POSSIBLE CONFIGURATIONS

For some models, the IM-RM series is available in versions:

- HTR
- Twin.

4.3.1 - HTR VERSION

An HTR (High Temperature Resistance) version conforming to EN 12480 is available for some meter models: 2002 Annex C/DVGW - test report: 17-134-4703-082.



Fig. 4.3. HTR Version

Technical features	
Housing material	Cast Iron EN-GJS-400-15 or EN-GJS-400-18LT
Flange connection	PN16 Flat-face
Maximum working pressure	16 bar (5 bar HTR)
Surface treatment	Painted Yellow (RAL1004)
Design Temperature range	-25 °C to +55 °C (-13°F to 131°F)
Operating temperature range	-20 °C to +60 °C

Tab. 4.17.

4.3.2 - TWIN VERSION

Twin Rotary meters:

- generate fewer pulsations on the gas line than the conventional meter;
- significantly limit ambient noise;
- can be equipped with an internal bypass to ensure continuity of gas supply even in the event of an emergency (blocked rotors, damaged meter,...). The bypass:
 - is automatically activated when the pressure drop value set by the manufacturer and agreed at the time of ordering is exceeded;
 - can only be rearmed after breaking the metrological seals.

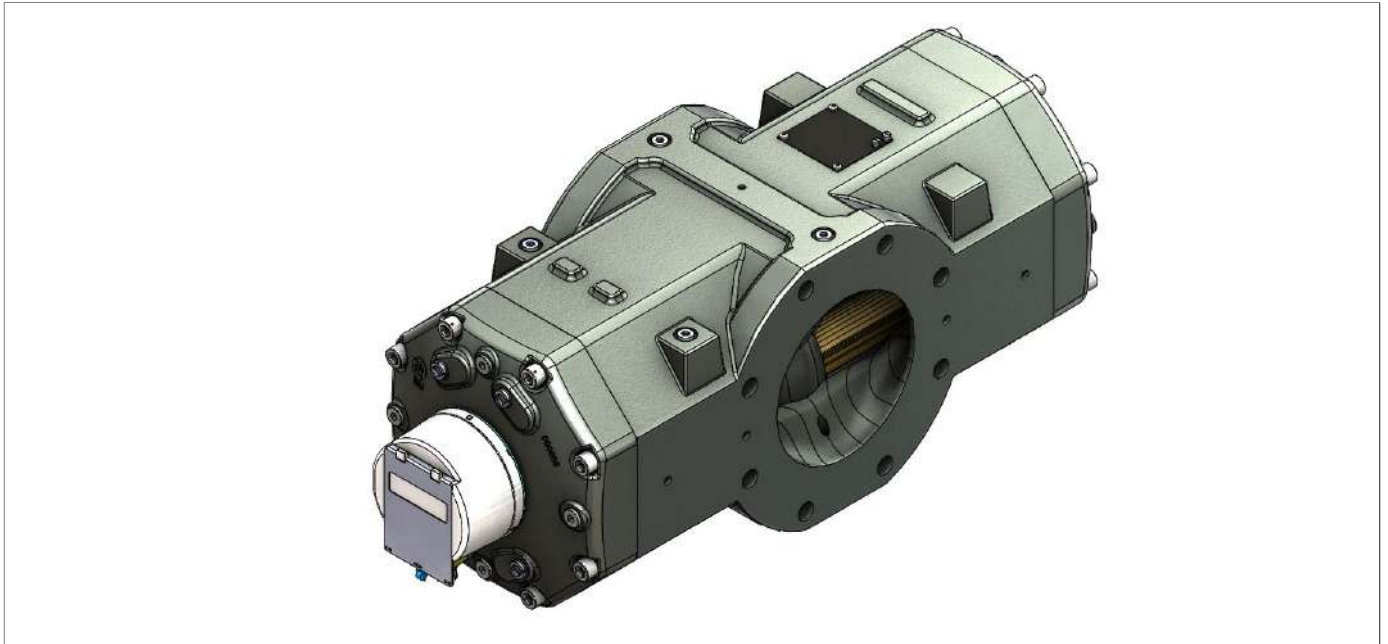

Fig. 4.4. Twin version

4.4 - TECHNICAL FEATURES/PERFORMANCE

The main specifications of the IM-RM series are:

Technical features	
Flow rates	from 0,5 m ³ /h to 1000 m ³ /h (from 17,6 cfm to 35314 cfm)
Design pressure (PS)	up to 2.5 MPa (up to 25 barg)
Room temperature	-25 °C to +55 °C (-13 °F to +131 °F)
Gas temperature	-25 °C to +55 °C (-13 °F to +131 °F)
Accuracy	$Q_{min} \leq Q < Q_t \pm 2\%$ and $Q_t \leq Q \leq Q_{max} \pm 1\%$ (Q_t according to EN12480)
Accuracy class	1.0
Rangeability	up to 1:250
Repeatability	better than 0.1%
Protection rating	IP 67
Applicable metrology standards	MID 2014/32/EU
Mechanical environmental class	M1
Electromagnetic environmental class	E1
Index & pulse out	<ul style="list-style-type: none"> • 8 digits. • 2x low frequency pulse out (NO reed contact). • 1x anti-fraud output (NC reed contact).
Hazardous area certification	ATEX II 2 G Ex h IIB T6 Gb
Accessories	<ul style="list-style-type: none"> • Optical encoder indicator. • High-frequency sensors. • By-pass valve on Twin versions.
Nominal dimensions DN	from DN 40 to DN 150
Connections	<ul style="list-style-type: none"> • Flange class 150 according to ASME B16.5. • PN 16/25 according to EN 1092-1. • G 1 ½" (ISO228-1) or NPT 1 ½" (ANSI B1.20.1) only for threaded connections of the 121 mm gauge version.
Pressure and temperature connections	1/4" NPT fem.

Tab. 4.18.

NOTICE!

Stated temperature ranges are the maximum for which the equipment's full performance, including accuracy, are fulfilled. Standard product may have a narrower range.

4.4.1 - MODEL CAPACITIES AVAILABLE

We list in Tab. 4.19 the capacities and measuring ranges of the available models:

Available sizes - Rated operating conditions								
Model	Q _{max}	Q _{min}	Field	DN	Cyclic volume	Flange-flange gauge	HTR Version	Pulses at low frequency
	m ³ /h	m ³ /h	max	-	dm ³	mm	Yes(v)/No(x)	Imp./m ³
G10	16	0.5	1:30	40	0.18	121	x	10
G16	25	0.5	1:50	40	0.18		x	10
G25	40	0.5	1:80	40	0.26		x	10
G16	25	0.5	1:50	40/50	0.69	171	v (DN50 only)	10
G25	40	0.5	1:80	40/50	0.69		v (DN50 only)	10
G40	65	0.5	1:130	40/50	0.69		v (DN50 only)	10
G65	100	0.5	1:200	50	0.69		v	10
G65	100	1	1:100	80	1.11		v	10
G100	160	1	1:160	50	1.11		x	1
G100	160	1	1:160	80	1.11		v	1
G100 Twin	160	1.6	1:100	80	1.73		x	1
G160 Twin	250	1.6	1:160	80	1.73		x	1
G100	160	1.6	1:100	80	2.31		241	v
G160	250	1.6	1:160	80	2.31	v		1
G100	160	2.5	1:65	100	2.98	v		1
G160	250	1.6	1:160	100	2.98	v		1
G250	400	2.5	1:160	100	2.98	v		1
G250 Twin	400	4	1:100	100	3.88	x		1
G400 Twin	650	4	1:160	100	3.88	x		1
G400 Twin	650	4	1:160	150	3.88	x		1
G400 Twin	650	6.5	1:100	150	5.97	x		1
G650 Twin	1000	6.5	1:160	150	5.97	x	1	

Tab. 4.19.



Standard rangeability values are shown in the table. Different values are available on request.

PAGE INTENTIONALLY LEFT BLANK

5 - TRANSPORT AND HANDLING





5.1 - SPECIFIC WARNINGS FOR TRANSPORT AND HANDLING

NOTICE!

Transport and handling must be carried out in compliance with the regulations in force in the country of installation by personnel who are:

- qualified (specially trained);
- who are familiar with accident prevention and workplace safety regulations;
- authorised to use lifting equipment.

Transport and handling

Operator qualification	<ul style="list-style-type: none"> • Person in charge of transport, handling, unloading and placing on site. • Installer.
PPE required	<div style="display: flex; align-items: center;">     </div> <div style="background-color: #f4a460; padding: 5px; margin-top: 5px;">  WARNING! </div> <p>The PPE listed in this table is related to the risk associated with the equipment. For the PPE required to protect against risks associated with the workplace, installation or operating conditions, please refer to:</p> <ul style="list-style-type: none"> • the regulations in force in the country of installation; • <u>any information provided by the Safety Manager at the installation facility.</u>
Weights and dimensions of the equipment	<p>For dimensions and weights, refer to paragraph 5.3 "Physical characteristics of the equipment".</p>

Tab. 5.20.

5.2 - PACKAGING AND FASTENERS USED FOR TRANSPORT

The transport packaging is designed and manufactured to avoid damage during normal transport, storage and handling. The equipment must be kept in the packaging until installation.

Upon receiving the equipment, please:

- make sure that no part has been damaged during transport and/or handling;
- immediately report any damage found to PIETRO FIORENTINI S.p.A..



ATTENTION!

The packaging features information in the form of either words and/or symbols to ensure correct handling.

NOTICE!

PIETRO FIORENTINI S.p.A. shall not be liable for any damage to people or property caused by accidents due to failure to comply with the instructions provided in this manual.

Tab. 5.21. describes the types of packaging used:

Ref.	Type of packaging	Image
A	Cardboard boxes on pallets.	
B	Single cardboard box on pallet.	
C	Single wooden crate prepared for forklift handling.	

Tab. 5.21.

5.2.1 - PACKAGING CONTENT

The packaging contains:

Description of content

- IM-RM meter;
- bottle of oil (sufficient for first lubrication);
- 6-pole connector for LF impulse emitter;
- calibration certificate;
- pressure test certificate;
- EU Declaration of Conformity;
- user, maintenance and warning manual.

Tab. 5.22.

NOTICE!

On specific request, the packaging may contain:

- **material certificates (according to EN 10204);**
- **conical or flat filter;**
- **gaskets and hardware for flanges;**
- **3 metre pre-wired cable for LF or HF emitter;**
- **fittings.**





NOTICE!

The IM-RM meter is then shipped without lubrication oil in the tanks.

NOTICE!

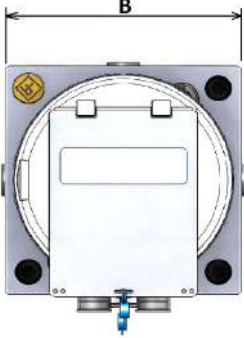
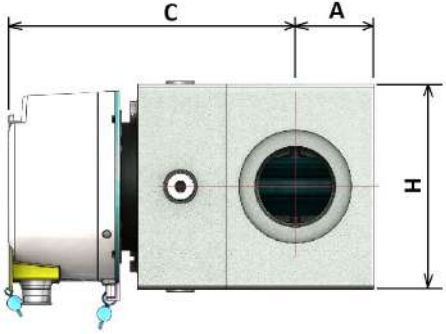
**The use, maintenance and warning manual can also be downloaded from the Manufacturer's website:
<https://www.fiorentini.com>**

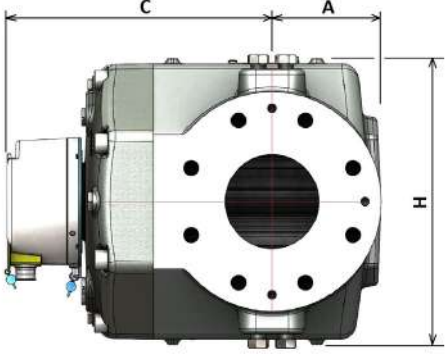
5.3 - PHYSICAL CHARACTERISTICS OF THE EQUIPMENT

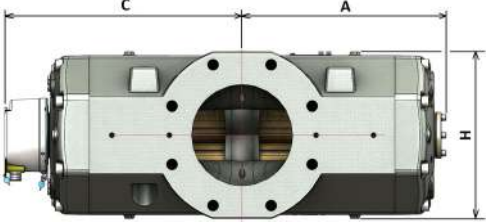
Flange-to-flange gauge	Image	
121 mm		
171 mm to 241 mm		
171 mm to 241 mm (Twin version)		

Tab. 5.23.

Dimensions					
Model	DN	A max	B ± 2mm	C max	H max
	-	mm	mm	mm	mm
G10	40	35	121	175	130
G16	40	35	121	175	130
G25	40	50	121	175	130
G16	40/50	85	171	190	185
G25	40/50	85	171	190	185
G40	40/50	85	171	190	185
G65	50	85	171	190	185
G65	80	100	171	220	185
G100	50	100	171	220	185
G100	80	100	171	220	185
G100 Twin	80	225	171	280	185
G160 Twin	80	225	171	280	185
G100	80	100	241	240	265
G160	80	100	241	240	265
G100	100	130	241	255	265
G160	100	130	241	255	265
G250	100	130	241	255	265
G250 Twin	100	255	241	305	265
G400 Twin	100	255	241	305	265
G400 Twin	150	255	241	305	265
G400 Twin	150	325	241	375	265
G650 Twin	150	325	241	375	265

Tab. 5.24.

Weights			
Model	Aluminium version	HTR Version	Cast iron version
	kg	kg	kg
G10	3.5	-	-
G16	3.5	-	-
G25	4	-	-
G16	10	23	23
G25	10	23	23
G40	10	23	23
G65	10	23	23
G65	12	-	30
G100	12	-	30
G100	12	30	30
G100 Twin	20.5	-	-
G160 Twin	20.5	-	-
G100	22.5	56	56
G160	22.5	56	56
G100	27.5	62	62
G160	27.5	62	62
G250	27.5	62	62
G250 Twin	45	-	-
G400 Twin	45	-	-
G400 Twin	45	-	-
G400 Twin	45	-	-
G400 Twin	45	-	-
G650 Twin	45	-	-

Tab. 5.25.

NOTICE!

The HTR version is resistant to high temperatures in accordance with Annex C of EN12480.

5.4 - EQUIPMENT ANCHORING AND LIFTING METHOD

HAZARD!

Using lifting equipment (if necessary) for unloading, carrying and handling packages is reserved only for skilled operators who have been properly trained (and are appropriately qualified if required by the regulations in force in the country of installation) and are familiar with:

- accident prevention rules;
- workplace safety provisions;
- lifting equipment features and limits.

HAZARD!

Before handling a load, make sure that its weight does not exceed the load capacity of the lifting equipment (and any other lifting tools) specified on the specific plate.

HAZARD!

- The eyebolts provided must only be used to lift the meter without additional loads.
- The lifting point is dimensioned to lift only the equipment and not other parts of the installation connected to it.

ATTENTION!

Before handling the packaging:

- remove any movable or hanging component or firmly secure it to the load;
- protect fragile equipment;
- check that the load is stable;
- make sure to have perfect visibility along the route.

ATTENTION!

Do not use the totaliser unit to lift and/or handle the meter.

ATTENTION!

The packaging features information in the form of either words and/or symbols to ensure correct handling.

NOTICE!

When handling the meter:

- the axes of the rotors must remain strictly horizontal;
- lubrication tanks must be free of lubricating oil.

5.4.1 - HANDLING WITH FORKLIFT TRUCK

HAZARD!

It is forbidden to:





- Do not transit under suspended loads;
- Do not move the load over the personnel operating in the site/plant area.

WARNING!

The following is not allowed on forklifts:

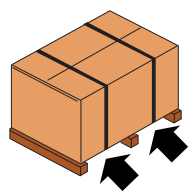
- carrying passengers;
- lifting people.

If cardboard boxes (single or multiple) are carried on a pallet, proceed as indicated in Tab. 5.26.:

Step	Action	Image
1	<p>Place the forks of the forklift under the load surface.</p> <p>ATTENTION! Always use both forks and maintain a distance between them of at least 50 cm.</p>	<p>1</p> 
2	<p>Make sure that the forks protrude from the front of the load (by at least 5 cm), far enough to eliminate any risk of the transported load tipping.</p>	<p>2</p> 
3	<p>Raise the forks until they are touching the load.</p> <p>NOTICE! Fasten the load to the forks with clamps or similar devices if required.</p>	<p>3</p> 
4	<p>Slowly lift the load by a few dozen centimetres and check its stability, making sure that the centre of gravity of the load is at the centre of the lifting forks.</p>	<p>4</p> 

Step	Action	Image
5	Tilt the mast backwards (towards the driver's seat) to help the over-turning moment and to ensure greater load stability during transport.	
6	Adjust transport speed according to the type of floor and load, avoiding sudden manoeuvres. ⚠ WARNING! In case of: <ul style="list-style-type: none"> • obstacles along the path; • particular operating situations; hinder operator visibility, the assistance of a ground operator is required, standing outside the range of action of the lifting equipment, with the task of signalling.	-
7	Place the load in the chosen installation/storage area.	-

Tab. 5.26.

5.4.2 - CRANE HANDLING

HAZARD!

Before handling the equipment, make sure that:

- the rope or chain intended for lifting has a maximum working load that exceeds the weight to be handled;
- the eyebolts are tightened.

HAZARD!

It is forbidden to:

- Do not transit under suspended loads;
- handling the equipment above the personnel working in the site/establishment area;
- use bars, handles or keys to tighten the eyebolts;
- use a single eyebolt to lift a load that is unsteady or free to rotate;
- feed the slings through the eyebolts or chains mounted on pairs of eyebolts;
- force hooks or other accessories into the eyebolts. The hooks must fit loosely;
- subject the eyebolts to impacts.

The equipment must be handled using the lifting points provided on the equipment itself. Proceed as shown in tab.5.27:

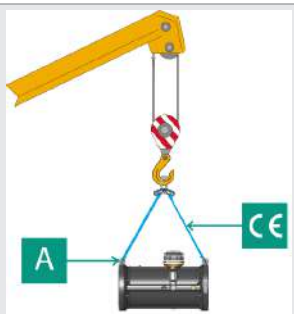
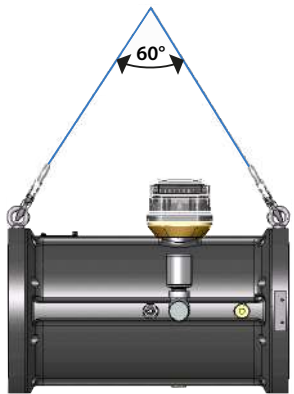
Step	Action	Image
1	Remove packaging (when necessary).	
2	Attach the lifting rope or chain to the lifting eyebolts (A) on the equipment. <div style="border: 1px solid blue; padding: 5px; margin-top: 10px;">  NOTICE! Mandatory use: <ul style="list-style-type: none"> • CE-marked chains, ropes and eyebolts; • all lifting eyebolts present. </div>	
3	Lift the equipment slightly, ensuring that: <ul style="list-style-type: none"> • the angle formed by the rope/chain for lifting does not exceed 60°; • the load is correctly balanced and the centre of gravity is centred. 	
4	Slowly lift the equipment while holding it horizontally.	
5	Place the load in the chosen installation/storage area.	-

Tab. 5.27.

5.5 - PACKAGING REMOVAL

Installation	
Operator qualification	<ul style="list-style-type: none"> Installer.
PPE required	<div style="display: flex; align-items: center;">  </div> <div style="background-color: #f9a825; padding: 5px; margin-top: 5px;"> ⚠ WARNING! </div> <p>The PPE listed in this table is related to the risk associated with the equipment. For the PPE required to protect against risks associated with the workplace, installation or operating conditions, please refer to:</p> <ul style="list-style-type: none"> the regulations in force in the country of installation; <u>any information provided by the Safety Manager at the installation facility.</u>
Equipment required	Refer to Chapter 7 'Commissioning/maintenance equipment'.

Tab. 5.28.

To unpack the equipment in a cardboard box, proceed as specified in Tab.5.29:

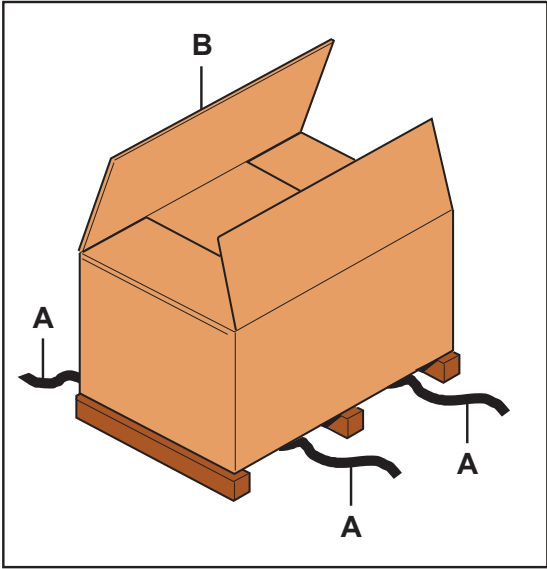
Step	Action	Image
1	Cut the strapping (A).	
	Remove the adhesive tape placed at the top of the cardboard box.	
2	Remove the packaging cardboard (B).	
3	Remove the fasteners that secure the equipment to the base (if any).	
4	Move the equipment from the carton to its designated place. <div style="background-color: #e6e6e6; padding: 5px; margin-top: 5px;"> ⚠ NOTICE! </div> <p>For manual handling of packages:</p> <ul style="list-style-type: none"> adopt correct posture; if their size/weight requires it, employ at least 2 operators. 	

Tab. 5.29.

To unpack the equipment in a wooden crate, proceed as specified in Tab.5.30:

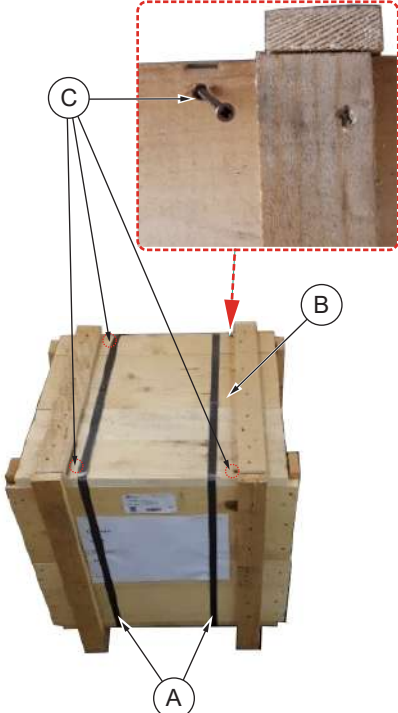
Step	Action	Image
1	Cut the strapping (A).	
2	Unscrew the screws (C) near the edges that secure the cover (B) of the crate. Equipment required for unscrewing screws: Phillips screw-driver.	
3	Remove the cover (B) of the crate.	
4	Move the equipment from the crate to its designated place. <div style="border: 1px solid blue; padding: 5px; margin-top: 10px;"> <p>NOTICE!</p> <p>For manual handling of packages:</p> <ul style="list-style-type: none"> adopt correct posture; if their size/weight requires it, employ at least 2 operators. </div>	

Tab. 5.30.

NOTICE!

After removing all packaging materials, check for any anomalies.

If there are anomalies:

- do not install the equipment;
- contact PIETRO FIORENTINI S.p.A. and specify the details provided on the equipment nameplate.

WARNING!

The individual equipment is contained in specially designed packaging. Avoid unpacking the equipment before installation.

5.5.1 - PACKAGING DISPOSAL

NOTICE!

Sort the various materials making up the packaging and dispose of them in compliance with the regulations in force in the country of installation.

5.6 - STORAGE AND ENVIRONMENTAL CONDITIONS

WARNING!

Protect the meter and flanges from blows and shocks, even accidental ones, until installation.

NOTICE!

- The meters must be stored inside their packaging in their original position (according to the indications on the packaging).
- Where no limits are indicated, stack a maximum of 2 packages.

NOTICE!

During meter storage:

- the axes of the rotors must remain strictly horizontal;
- lubrication tanks must be free of lubricating oil.

If the equipment needs to be stored for an extended period, the minimum environmental conditions for the intended storage are provided in Tab.5.31. Compliance with these conditions will guarantee the declared performance:

Conditions	Data
Maximum storage period	Maximum 6 years.
Storage temperature	from -10°C to + 25°C
Relative humidity storage environment	Less than 65% in non-condensing atmosphere.
Radiation and light sources	Away from radiation and light sources according to UNI ISO 2230:2009

Tab. 5.31.

5.6.1 - STORAGE LASTING LONGER THAN THE MAXIMUM TIME ALLOWED

NOTICE!

After a storage period exceeding the maximum permitted (6 years), contact PIETRO FIORENTINI S.p.A.

6 - INSTALLATION

6.1 - SPECIFIC SAFETY WARNINGS

WARNING!

The installation must be performed by qualified personnel, in compliance with the provisions in force concerning safety.

WARNING!

It is strictly forbidden to make any modifications to the equipment.

WARNING!

Installation may also take place in areas where there is a risk of explosion, which implies that all necessary prevention and protection measures have to be taken.

For these measures, please refer to the regulations in force at the place of installation.

WARNING!

Near the equipment, do not:

- use open flames (e.g. for welding operations);
- smoke.

ATTENTION!

PIETRO FIORENTINI S.p.A. is not liable for damage caused by incorrect installation of the equipment and/or otherwise different from that indicated in this manual.

6.2 - INSTALLATION PRE-REQUISITES

6.2.1 - ALLOWED ENVIRONMENTAL CONDITIONS

WARNING!

For the safe use of the equipment and its accessories, if any, observe the permissible environmental conditions and comply with the data on the identification plates (refer to section 2.8 "Applied rating plates").

WARNING!

The equipment must be installed away from atmospheric agents and direct sunlight.

ATTENTION!

PIETRO FIORENTINI S.p.A. is not liable for damage and/or malfunctions caused by installation in environments other than those permitted.

NOTICE!

For details of permissible environmental conditions (temperature range and classification), please refer to section 4.4 'Specifications/Performance'.

The installation site must be suitable for the safe use of the equipment.

The installation area of the equipment must be properly lit to ensure proper operator visibility during working on the equipment.

6.2.2 - STORAGE LASTING LONGER THAN THE MAXIMUM TIME ALLOWED

WARNING!

- Installing the equipment after storage exceeding the maximum admissible time (6 years) is not allowed.
- After a storage period exceeding the maximum permitted (6 years), contact PIETRO FIORENTINI S.p.A.

6.2.3 - CHECKS BEFORE INSTALLATION

HAZARD!

The T6 marking on the meter does not take into account the gas group and temperature classes of separately certified electrical devices (such as the optical encoder).

WARNING!

Before proceeding with the installation phase, make sure that:

- the line pressure does not exceed P_{max} ;
- the upstream and downstream valves installed on the line are closed and the pressure released.

WARNING!

The maximum permissible pressure (P_{max}) of rotary meters IM-RM is stated on the nameplate (refer to Section 2.8 'Applied rating plates').

Each piece of equipment is subjected to:

- resistance test (1.5 times P_{max});
- leak test (1.1 times the P_{max}).

ATTENTION!

Never use the meter as a spacer while welding.

ATTENTION!

If the installation of the equipment requires the application of compression fittings, these must be installed in accordance with the instructions of the Manufacturer of the fittings themselves.

The choice of fittings must be compatible with:

- the use specified for the equipment;
- the plant specifications when required.

ATTENTION!

Installation must not be carried out in the presence of dirt, welding residue or water in the pipes.

The pipework on the inlet side of the meter must be carefully cleaned (it is recommended to install a 100 μm filter upstream of the meter).

NOTICE!

We recommend the installation of a temporary wire mesh filter (250 μm) for new installations in the first weeks of operation.

Remove the temporary filter within a maximum of 2/3 months after installation (UNI 9167).

Before installation, it must be ensured that:

- the intended installation space (or the place reserved for installation) meets current safety requirements and is protected from possible mechanical damage, away from heat sources or open flames, in a dry place and protected from external agents;
- there are no obstructions that could hinder installation operations or subsequent maintenance operations;
- sufficient distance has been provided at the back of the meter for filling/changing the oil in the Twin version;
- the flow direction is respected as indicated on the nameplate (see section 2.8 of the manual). If the flow direction is incorrect, the meter must be replaced with one with the right flow direction;
- the meter rotors rotate freely;
- at least one shut-off valve is installed upstream;
- the meter is intact in all its parts/components and has not been damaged during handling;
- the upstream and downstream pipes are at the same level and able to bear the weight of the meter;
- the pipe inlet and outlet connections are parallel and clean;
- on the input and output connections are totally free of mechanical stress. The meter must be installed with no mechanical stress due to misalignment in the pipes;
- the seals are new and suitable (size and pressure rating) for the installation.

6.3 - GENERAL INFORMATION ON THE LINE

The device must be installed in the line, with the arrow on its body pointing to the gas flow direction.

Depending on the flow direction, the IM-RM meters can be configured in 3 different modes:

1. **Single position:** left to right & top to bottom
2. **Single position:** right to left & bottom to top
3. **Multiposition:** all flow directions are possible.

This configuration involves pressure outlets and temperature measurement points on both sides of the meter. These accessories can be supplied already assembled in the correct position or supplied separately.

6.3.1 - MOUNTING POSITION AND FLOW DIRECTION

Tab. 6.32 The location of the ports **P_m** (measuring pressure), **T** (measuring temperature) and **p** (pressure) is shown, as an example, for meters in 'Multiposition' mode.

The reference indications also apply in the same way to 'Single Position' mode configurations.

The numeric indicator (A) can be rotated approximately 350° to switch between horizontal and vertical positions.

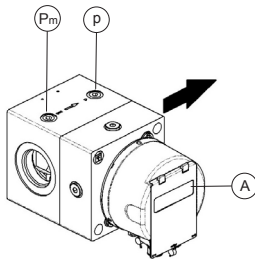
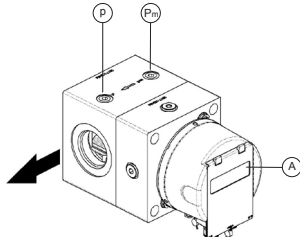
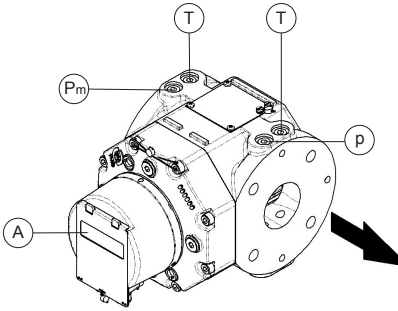
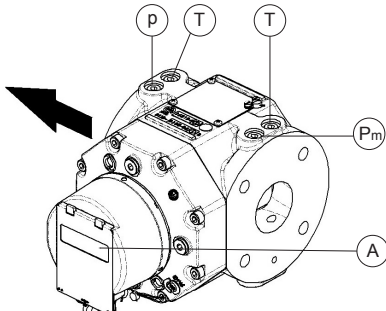
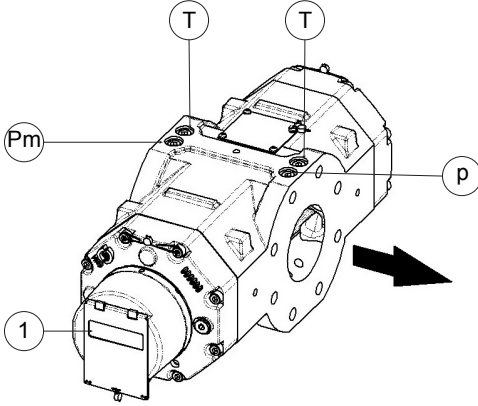
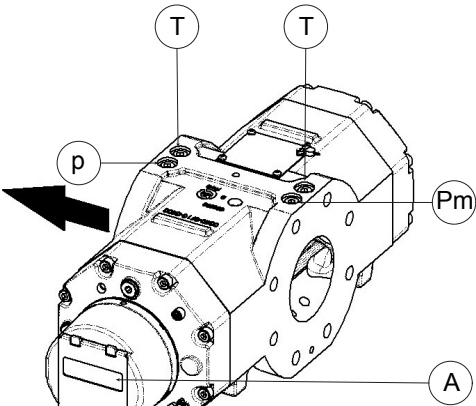
Flow direction	Distance flange-flange	Images	
Horizontal	121 mm		
Horizontal	171-241 mm		
Horizontal	171-241 mm Twin		

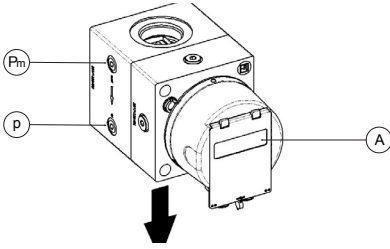
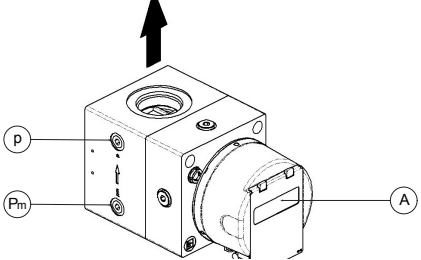
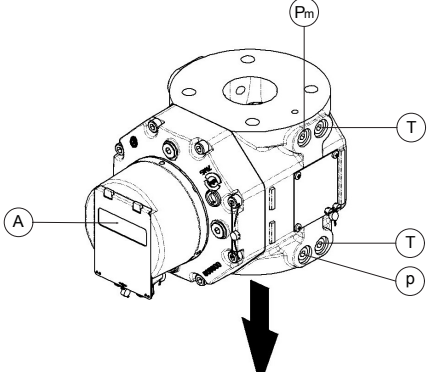
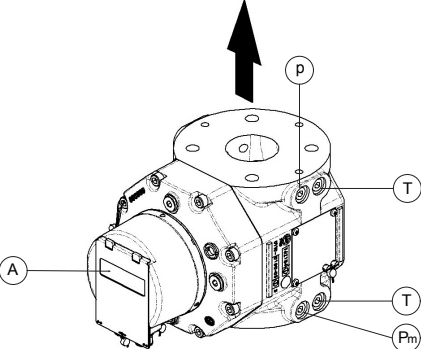
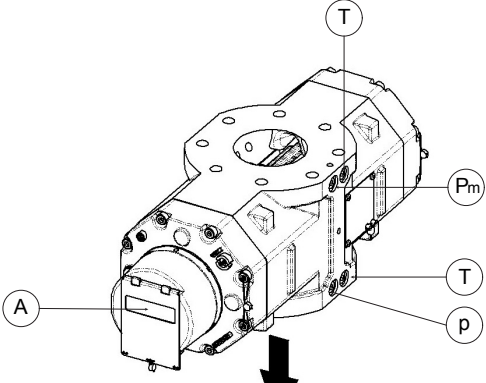
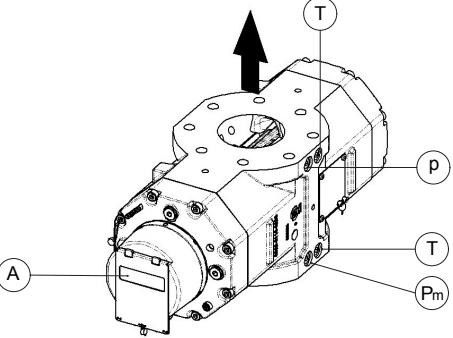
Flow di- rection	Distance flange-flange	Images	
Vertical	121 mm		
Vertical	171-241 mm		
Vertical	171-241 mm Twin		

Tab. 6.32.

6.4 - INSTALLATION PROCEDURES

Installation	
Operator qualification	<ul style="list-style-type: none"> • Installer.
PPE required	 <p>WARNING!</p> <p>The PPE listed in this table is related to the risk associated with the equipment. For the PPE required to protect against risks associated with the workplace, installation or operating conditions, please refer to:</p> <ul style="list-style-type: none"> • the regulations in force in the country of installation; • <u>any information provided by the Safety Manager at the installation facility.</u>
Equipment required	Refer to Chapter 7 'Commissioning/maintenance equipment'.

Tab. 6.33.

6.4.1 - EQUIPMENT INSTALLATION

ATTENTION!



During the installation of the meter, the oil tanks must be empty. Fill the lubricating oil tanks only after installation is complete.

NOTICE!

- Installation of the meter at the lowest point in a metering system should be avoided, as liquids and dirt tend to collect at the bottom.
- The meter flanges and gaskets must be cleaned before installation and free of foreign material.
- The axis of the meter rotors must always remain horizontal.

To install the equipment, proceed as specified in Tab.6.34.:

Step	Action
1	Apply the checks and controls of section 6.2.3 ("Checks before installation"). <p>NOTICE!</p> <p>In order to avoid the collection of impurities and condensation in the pressure outlet pipes, it is recommended that the bore on the pipe does not have any burrs or internal residues.</p>
2	Remove any packaging/protection of the equipment (adhesive covers are applied to each meter on the inlet and outlet flanges as protection from dirt, dust and water). <p>NOTICE!</p> <p>For proper disposal of packaging, please refer to the regulations in force in the country where the equipment is installed.</p>
3	Position the equipment in the section of the line designated for it. <p>NOTICE!</p> <p>The orientation of the equipment within the line must correspond to the direction of gas flow.</p>
4	Place the gaskets between the line flanges and the meter flanges.
5	Level the meter horizontally by no more than 5 mm/m in both directions (flow direction and direction perpendicular to the flow).

Step	Action
6	Insert the bolts into the appropriate holes in the connecting flanges and secure them.  NOTICE! See section 6.4.1.1 'Tightening torques'.
7	Make electrical connections.  NOTICE! See section 6.4.2 'Electrical Connections'.
8	Fill the oil tanks.  NOTICE! See section 6.6 'Lubrication'.

Tab. 6.34.

6.4.1.1 - TIGHTENING TORQUES

ATTENTION!

Use bolts:

- with minimum strength class 8.8 or stainless steel A2;
- for Class 150 flanging (ASTM A193 grade B8 or B7 products).

ATTENTION!

On the 'p' and 'Pm' connections:

- the maximum tightening torque is 30 Nm;
- to tighten the coupling, use 2 spanners (17 mm) to prevent the fittings from rotating.

DN	Threaded connection	Flange PN 10 / 16	ANSI 150 flanges	Max torque
DN40 (1 ½")	BSPP G 1 ½"	-	-	100 Nm
DN40 (1 ½")	-	4 threaded holes M16x24 mm	4 threaded holes 1/2" UNCx19 mm	55 Nm
DN 50 (2")	-	4 threaded holes M16x24 mm	4 threaded holes 5/8" UNCx24 mm	130 Nm
DN 80 (3")	-	8 threaded holes M16x24 mm	4 5/8" UNCx19 threaded holes	130 Nm
DN 100 (4")	-	8 threaded holes M16x24 mm	8 5/8" UNCx24 threaded holes	130 Nm
DN 150 (6")	-	8 M20x24 threaded holes	8 3/4" UNCx24 threaded holes	180 Nm

Tab. 6.35.

6.4.2 - ELECTRICAL CONNECTIONS

Installation	
Operator qualification	<ul style="list-style-type: none"> • Installer. • Electrical maintenance technician.
PPE required	<div style="display: flex; align-items: center;">  </div> <div style="background-color: #f4a460; padding: 5px; margin-top: 5px;"> <p>⚠ WARNING!</p> </div> <p>The PPE listed in this table is related to the risk associated with the equipment. For the PPE required to protect against risks associated with the workplace, installation or operating conditions, please refer to:</p> <ul style="list-style-type: none"> • the regulations in force in the country of installation; • <u>any information provided by the Safety Manager at the installation facility.</u>
Equipment required	Refer to Chapter 7 'Commissioning/maintenance equipment'.

Tab. 6.36.

⚠ HAZARD!

Around the meter, a potentially explosive atmosphere may be present due to the presence of gases, the extent of which varies depending on the meter:

- the type of gas;
- ventilation;
- the size of the fault etc.

The classification of danger areas is the responsibility of the customer/installer.

⚠ HAZARD!

When the product is installed in an area with a potentially explosive atmosphere:

- use only intrinsically safe circuits for connections;
- Only install devices with suitable EX protection.

⚠ WARNING!

Electrical connections must only be carried out by qualified personnel with knowledge of the protection classes, standards and regulations for equipment in potentially explosive atmospheres.

Before proceeding with electrical connections, check that:

- the electrical circuits are intrinsically safe;
- the planned operations take into account the classification of the areas.

6.4.2.1 - LOW-FREQUENCY SENSOR IMPULSE OUTPUT (LF)

NOTICE!

The low-frequency (LF) pulse generator of the IM-RM meters is a simple component as defined by EN60079-11 that does not require EX marking.

Only connect the output of the LF pulse generator to intrinsically safe circuits: the emitter characteristics are summarised in Tab. 6.37:

U _i	I _i	P _i	C _i	L _i
15 V	50 mA	120 mW	Negligible	Negligible
ATEX marking		II 2G Ex ib IIB T6 Gb		
Room temperature		MAX +70°C		

Tab. 6.37.

The LF pulse generator is available in different Pinout configurations, the main ones are listed below:

STANDARD CONFIGURATION OF THE P/N 0050-8100-0100/0126 PULSEBOX PINS

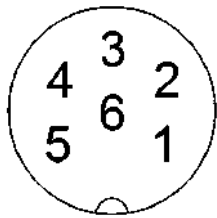

1 - 4 Count 1

2 - 5 Count 2

3 - 6 NC surveillance

The impulse value is reported on the nameplate (e.g.: 1 imp = 1 m³)

SPECIAL CONFIGURATION OF THE P/N 0050-8100-0112 PULSEBOX PINS

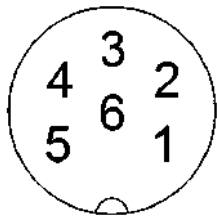

1 - 2 Count 1

5 - 6 Count 2

3 - 4 NC surveillance

The impulse value is reported on the nameplate (e.g.: 1 imp = 1 m³)

SPECIAL CONFIGURATION OF THE P/N 0050-8100-0122 PULSEBOX PINS

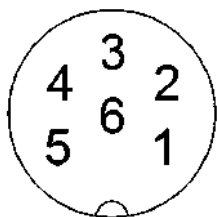

Connector I

4 - 6 Count 1

1 - 2 NC surveillance

The impulse value is reported on the nameplate (e.g.: 1 imp = 1 m³)

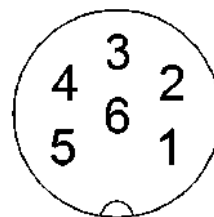

Connector II

3 - 5 Count 2

SPECIAL CONFIGURATION OF THE P/N 0050-8100-0125 PULSEBOX PINS

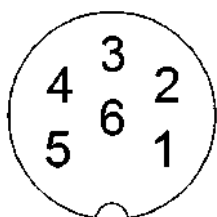

Connector I

1 - 4 Count 1

3 - 6 NC surveillance

The impulse value is reported on the nameplate (e.g.: 1 imp = 1 m³)

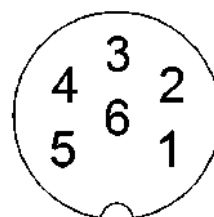

Connector II

2 - 5 Count 2

! NOTICE!

For the electrical features and pin configuration of the Optical Encoder series 0050-7000-04xx refer to the relevant manual TOD04107 and to the data reported on the encoder label.

6.4.2.2 - HIGH-FREQUENCY (HF) SENSOR IMPULSE OUTPUT

The 2-wire high-frequency sensor, when energised, varies the current it draws according to the energised/un-energised state.

The switching amplifier (when present), limits:

- voltage;
- the sensor current according to NAMUR EN 60947-5-6; avoiding ignition risks.

Only connect the output of the HF pulse emitter to intrinsically safe circuits: the emitter characteristics are summarised in Tab. 6.38:

Marking ATEX	Temperature environment	U _i (Vdc)	I _i (mA)	P _i (mW)	C _i (nF)	L _i (µH)
II 1G Ex ia IIC T4 ... T6 Ga	Max +60°C	20	60 (resistively limited)	150	150	150

Tab. 6.38.

The HF pulse generator is available in two Pinout configurations:

STANDARD CONFIGURATION OF THE HIGH-FREQUENCY (HF) IMPULSE OUTPUT

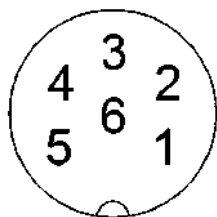

3 (-) 6 (+) Impulse output

SPECIAL HIGH FREQUENCY (HF) PULSE OUTPUT CONFIGURATION

5 (-) 6 (+) Impulse output

The impulse value is reported on the nameplate (e.g.: 1200 imp/m³)

If a preassembled cable is supplied with the connector, the pin-colour correspondence is as follows:

1. White
2. Brown
3. Green
4. Yellow
5. Grey
6. Pink

6.5 - POST-INSTALLATION INSTRUCTIONS

WARNING!

Ensure that all connections (hydraulic, mechanical and electrical) are:

- properly connected;
- tightened correctly to prevent any leakage during commissioning.

ATTENTION!

After completion of the equipment installation, a pressure test must be carried out. In the event of a leak, take appropriate measures to solve it.

6.6 - LUBRICATION



The meter comes with a bottle containing the initial amount of lubricating oil. The amount of oil supplied depends on the type of meter and the intended installation location.

ATTENTION!

- The meter must not be lubricated before it is been installed.
- During filling and topping up of the oil, the meter must be out of service and pressure-free.

NOTICE!

When filling or topping up tanks, use only Shell Morlina 10 + colour agent C.I.26000 oil supplied by PIETRO FIORENTINI S.p.A.

Lubrication	
Operator qualification	<ul style="list-style-type: none"> • Mechanical maintenance technician. • Installer. • Name of the user.
PPE required	<div style="display: flex; align-items: center;">  </div> <div style="background-color: #f4a460; padding: 5px; margin-top: 5px;">  WARNING! </div> <p>The PPE listed in this table is related to the risk associated with the equipment. For the PPE required to protect against risks associated with the workplace, installation or operating conditions, please refer to:</p> <ul style="list-style-type: none"> • the regulations in force in the country of installation; • any information provided by the Safety Manager at the installation facility.
Equipment required	Refer to Chapter 7 'Commissioning/maintenance equipment'.

Tab. 6.39.

The oil tanks must be filled with lubricating oil after installation but before commissioning via the filler cap (A) provided. The correct filling level is in the centre of the level indicator (B). In case there are several oil level sight glasses on the meter, the reference sight glass (B) is always the lowest in the final installation position. Transport, handling and deinstallation must be carried out without oil in the tanks. Drain the oil from the tanks via the drain plug (C).

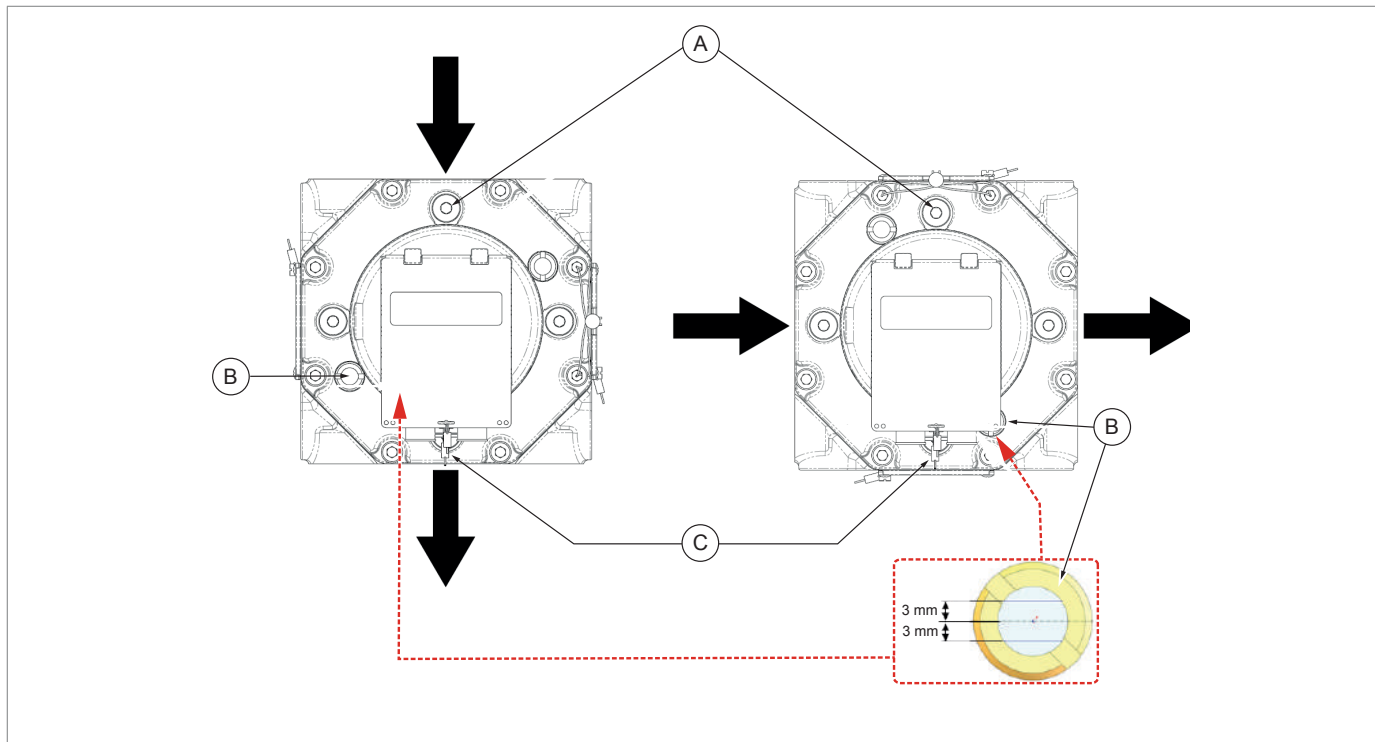

Fig. 6.5. Lubrication

6.6.1 - FILLING THE OIL TANKS

! NOTICE!

For filling the tanks, use only Shell Morlina 10 + colour agent C.I.26000 oil supplied by PIETRO FIORENTINI S.p.A.

! NOTICE!

The standard oil bottle (250 ml = 250 cm³) contains more oil than required for initial installation.

The amount of oil required for the different versions is shown in Tab.6.40:

Flange-flange gauge	Position with horizontal flow	Position with vertical flow
121 mm	15 cm ³	35 cm ³
171 mm	25 cm ³	120 cm ³
171 mm (Twin version) *	25 cm ³ + 25 cm ³	120 cm ³ + 120 cm ³
241 mm	60 cm ³	345 cm ³
241 mm (Twin version) *	60 cm ³ + 60 cm ³	345 cm ³ + 345 cm ³

* for the Twin version fill both the front and rear tanks

Tab. 6.40.

To fill the oil tanks, proceed as shown in Tab.6.41:

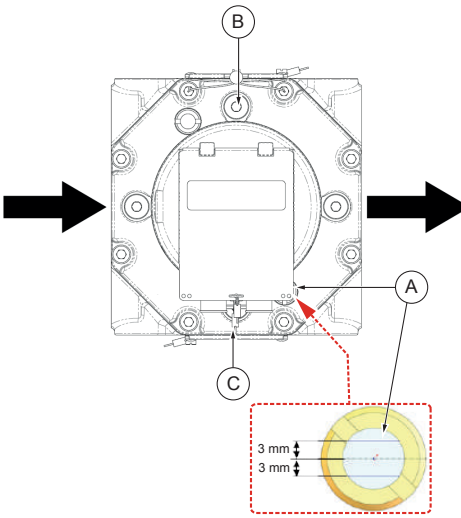
Step	Action	Image
1	Check that the drain plug (C) on the meter is tightened. Equipment required: 1/4" Allen key AF.	
2	Open the filler cap (B) of the meter. Equipment required: 1/4" Allen key AF.	
3	Fill the tank with the type of oil recommended by PIETRO FIORENTINI S.p.A. until the correct filling level indicated on the level indicator (A) is reached. NOTICE! The oil bottle is fitted with a spout.	
4	Replace the sealing o-ring of the filler cap (B).	
5	Close the filler cap (B) of the meter. Equipment required: 1/4" Allen key AF.	

Tab. 6.41.

NOTICE!

Check the seals at the end of filling.





7 - COMMISSIONING/MAINTENANCE EQUIPMENT

7.1 - LIST OF EQUIPMENT

Use of commissioning/maintenance equipment	
Operator qualification	<ul style="list-style-type: none"> • Mechanical maintenance technician. • Electrical maintenance technician. • Installer. • Name of the user.
PPE required	<div style="display: flex; align-items: center;">  </div> <div style="background-color: #f4a460; padding: 5px; margin-top: 5px;"> <p>⚠ WARNING!</p> </div> <p>The PPE listed in this table is related to the risk associated with the equipment. For the PPE required to protect against risks associated with the workplace, installation or operating conditions, please refer to:</p> <ul style="list-style-type: none"> • the regulations in force in the country of installation; • any information provided by the Safety Manager at the installation facility.

Tab. 7.42.

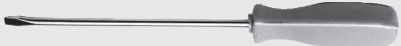
The types of equipment required for the installation, commissioning and maintenance of the regulator are listed in Table 7.43:

Ref.	Equipment type	Image
A	Combination spanners 17 - 24 - 30 mm	
B	Allen key bent 1/4" AF.	
C	Phillips screwdriver.	
D	Slotted screwdriver.	
E	Torque wrench.	

Tab. 7.43.

PAGE INTENTIONALLY LEFT BLANK

8 - COMMISSIONING

8.1 - GENERAL WARNINGS

8.1.1 - SAFETY REQUIREMENTS FOR COMMISSIONING

HAZARD!

During commissioning the risks associated with any discharges to the atmosphere of flammable or noxious gases must be evaluated.

HAZARD!

In case of installation on distribution networks for natural gas, consider the risk associated with explosive mixtures (gas/air) being formed inside the piping, if the line is not subjected to inerting.



WARNING!

During commissioning, any unauthorised personnel must keep away.
The commissioning area must be marked with signs and/or boundaries.

NOTICE!

Commissioning has to be carried out by authorised and qualified personnel.

Commissioning

Operator qualification	<ul style="list-style-type: none"> • Installer. • Name of the user.
PPE required	<div style="display: flex; align-items: center;">  </div> <div style="background-color: #f96; padding: 5px; margin-top: 5px;">  WARNING! </div> <p>The PPE listed in this table is related to the risk associated with the equipment. For the PPE required to protect against risks associated with the workplace, installation or operating conditions, please refer to:</p> <ul style="list-style-type: none"> • the regulations in force in the country of installation; • any information provided by the Safety Manager at the installation facility.
Equipment required	Refer to Chapter 7 'Commissioning/maintenance equipment'.

Tab. 8.44.

8.2 - PRELIMINARY PROCEDURES FOR COMMISSIONING

HAZARD!

The IM-RM meter can be used to measure gas at high or low temperatures.
Avoid contact with the meter when in service.

WARNING!

Before commissioning, it must be ensured that:

- the conditions of use comply with the characteristics of the equipment;
- during pressurisation, the equipment has no leaks.

ATTENTION!

The IM-RM meter:

- must be considered part of the pressurised system;
- must not be used outside the limits indicated on the nameplate attached and inside this manual.

NOTICE!

Removing or damaging the metrological seals could invalidate the calibration.

Before commissioning the equipment, it is necessary to check:

- that the conditions of use are in accordance with the characteristics of the equipment;
- that all on/off valves (inlet, outlet, bypass if applicable) are closed;
- that the gas is at a temperature and pressure within the limits indicated on the nameplate attached (see section 2.8);
- that any source of ignition has been eliminated.

8.3 - METER COMMISSIONING

! NOTICE!

Commissioning has to be carried out by authorised and qualified personnel.

Start-up can be carried out using two different procedures:

1. Pressurising the equipment by inserting an inert fluid (e.g. nitrogen) to avoid potentially explosive mixtures.
2. Direct insertion of gas into the pipes.

To commission the meter, proceed as described in Tab. 8.45.:

Step	Action
1	Open any bypass valve and the outlet valve downstream of the meter.
2	Partially open the meter inlet gas valve until the meter starts to run at low speed. ! NOTICE! <ul style="list-style-type: none"> • Pressurise the meter carefully while maintaining a pressure gradient of no more than 35 kPa/s (0.35 bar/s). • You probably will need to partially close the bypass valve to start the flow of gas through the meter.
3	Verify that gas flows through the meter by observing the movement of the digits on the totaliser assembly: <ul style="list-style-type: none"> • if movement is present, proceed with Step 4; • if the digits do not move, check that the gas flows to the meter. If the gas flows proceed with Step 5.
4	Let the meter run at low speed for a few minutes while listening for any unusual sounds or vibrations (scraping, beating, etc.). If operation is satisfactory, proceed to Step 6 .
5	If there are unusual sounds and vibrations (Step 4) or if the digits on the totalising unit do not move (Step 3): <ol style="list-style-type: none"> 1. interrupt the commissioning procedure; 2. slowly depressurise the meter; 3. safely vent the pressure; 4. check for misalignments, deformations, pipe torsions or other related problems (see Chapter 10 'Trouble-shooting'); 5. Resume, if the problem is solved, the commissioning procedure from Step 1.
6	Gradually open the inlet valve by pressurising the meter. ! NOTICE! <p>Pressurise the meter carefully while maintaining a pressure gradient of no more than 35 kPa/s (0.35 bar/s).</p>
7	Gradually close the bypass valve.
8	Follow the user's company procedures or current practice to check for leaks: <ul style="list-style-type: none"> • of the meter; • of the external surfaces; • of all connections. ! NOTICE! <p>Current practice envisages the use of: gas analysers, soapy water, foaming solutions or leak detector sprays for the final inspection of seals.</p>
9	Meter conditions can be deduced from the pressure absorption (point P _m versus point p). We recommend recording the pressure drop at various flow rates during installation. This value can be compared with a future measurement.

Tab. 8.45.

9 - MAINTENANCE AND FUNCTIONAL CHECKS

9.1 - GENERAL WARNINGS

HAZARD!

- No maintenance or inspection work is permitted while the meter is pressurised or in operation.
- Repair or maintenance work not provided for in this manual may be carried out only if approved by PIETRO FIORENTINI S.p.A.. PIETRO FIORENTINI S.p.A. shall not be held liable for damage to persons or property resulting from operations other than those described herein or carried out in ways other than as indicated.

HAZARD!

Maintenance operations:

- require extensive and specialised knowledge of the machines, operations required, risks involved and correct procedures to operate safely;
- are reserved for qualified, educated, recognised and authorised operators by PIETRO FIORENTINI S.p.A.

HAZARD!

Maintenance operators must be aware of the measures to be taken to prevent possible causes of ignition (e.g. production of sparks, electrostatic charges, etc.)

WARNING!

If it is necessary to remove the meter from the line on which it is installed, it is necessary to:

- depressurise the system;
- drain the oil.

WARNING!

Never carry out hydraulic tests or oil hydraulic tests.
Water or any other liquid causes damage to the meter.

WARNING!

- Always follow the operating frequencies indicated in the manual for scheduled maintenance (preventive and periodic). The time interval between interventions is to be understood as the maximum acceptable and must never be exceeded.
- Promptly check the causes of any anomalies such as excessive noise, leakage of fluids or similar and remedy them. The timely removal of any causes of anomaly or malfunction avoids further damage to the equipment and ensures operator safety.

WARNING!

In case of doubt, do not perform any work. Contact PIETRO FIORENTINI S.p.A. for the necessary clarifications.

NOTICE!

Maintenance work is strictly related to:

- the quality of the conveyed gas (impurities, humidity, gasoline, corrosive substances);
- the state of cleanliness and preservation of the pipes upstream of the meter;
- the level of reliability required of the measurement system;
- the equipment conditions of use.

9.2 - MAINTENANCE OPERATIONS

The management and/or use of the equipment includes interventions that are necessary as a result of normal use such as:

- inspections and controls;
- functional checks;
- routine maintenance;
- special maintenance.

Before starting maintenance on the equipment, it is advisable to make sure that the authorised operator has:

- of original/recommended spare parts;
- the necessary equipment (see Chapter 7 'Commissioning/maintenance equipment').

The equipment maintenance operations are divided, from an operational point of view, into two main categories:

Maintenance Operations	
Routine maintenance	All those operations that the operator has to perform: <ul style="list-style-type: none"> • periodically for maintenance and operation of the equipment; • preventively to ensure proper functioning of the device over time.
Special maintenance	All those operations to be carried out by the operator as required by the equipment.

Tab. 9.46.

9.2.1 - OPERATIONS PRIOR TO MAINTENANCE

Before proceeding with maintenance operations, it must be ensured that:

- the meter is secure;
- the line on which the meter is installed is intercepted upstream and downstream;
- the line on which the meter is installed has been depressurised.

9.3 - ROUTINE MAINTENANCE



 **HAZARD!**

It is forbidden to carry out inspections, checks and maintenance if the meter is pressurised or in operation. Before an inspection, control or maintenance, check that:

- the equipment is in a safe condition:
 1. close the downstream shut-off valve;
 2. close the upstream shut-off valve;
 3. completely discharge the line.
- the pressure upstream and downstream of the equipment is “0”.

 **WARNING!**

In case of doubt, do not perform any work. Contact PIETRO FIORENTINI S.p.A. for the necessary clarifications.

Routine maintenance	
Operator qualification	<ul style="list-style-type: none"> • Mechanical maintenance technician. • Name of the user.
PPE required	<div style="display: flex; align-items: center;">  <div style="background-color: #e69a00; color: white; padding: 5px; display: flex; align-items: center;">  WARNING! </div> </div> <p>The PPE listed in this table is related to the risk associated with the equipment. For the PPE required to protect against risks associated with the workplace, installation or operating conditions, please refer to:</p> <ul style="list-style-type: none"> • the regulations in force in the country of installation; • any information provided by the Safety Manager at the installation facility.
Equipment required	Refer to Chapter 7 'Commissioning/maintenance equipment'.

Tab. 9.47.

9.3.1 - PERIODICALLY CHECKING AND INSPECTING THE EQUIPMENT FOR PROPER OPERATION

Table 9.48 lists the periodic checks and inspections:

Activity description	Equipment/accessories involved	Evaluation criterion	Minimum frequency
Significant performance check*	Meter IM-RM	Pressure absorption (comparing with that recorded during installation).	Half-yearly
		Correct totalisation.	Half-yearly
Visual inspection	Meter IM-RM	No visible damage.	Half-yearly
		Absence of noise.	Half-yearly
		Oil level through sight glass.	Half-yearly
		Tightening of connections.	Half-yearly
		Integrity of connecting cables.	Half-yearly

* These checks can be carried out remotely in the presence of a remote control system capable of sending signals/alarms when pre-set thresholds are reached.

Tab. 9.48.

9.3.2 - TOPPING UP OIL

NOTICE!



For topping up, use only **Shell Morlina 10 + colour agent C.I.26000** oil supplied by **PIETRO FIORENTINI S.p.A.**

Check the amount of oil in the meter periodically (at least twice a year).

The correct filling level is in the centre of the level indicator (A). In case there are several oil level sight glasses on the meter, the reference sight glass (A) is always the lowest in the final installation position.

If, when checked, the oil level is approx. 3 mm below the normal level in the middle of the sight glass (A), add oil until normal.

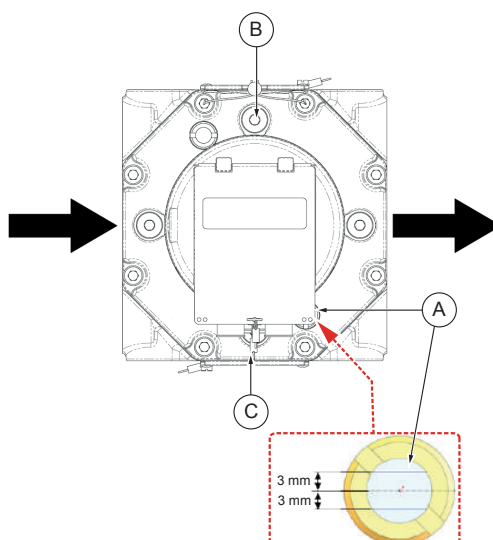
To top up, proceed as shown in Tab.9.49:

Step	Action	Image
1	Relieve the pressure.	
2	Open the filler cap (B) of the meter. Equipment required: 1/4" Allen key AF.	
3	Fill the tank with the type of oil recommended by PIETRO FIORENTINI S.p.A. until the correct filling level indicated on the level indicator (A) is reached.  NOTICE! The oil bottle is fitted with a spout.	
4	Replace the sealing o-ring of the filler cap (B).	
5	Close the filler cap (B) of the meter. Equipment required: 1/4" Allen key AF.	

Tab. 9.49.

NOTICE!

Check the seals at the end of maintenance.

9.3.3 - OIL CHANGE

! NOTICE!

When changing oil, use only **Shell Morlina 10 + colour agent C.I.26000** oil supplied by **PIETRO FIORENTINI S.p.A.**

! NOTICE!

The standard oil bottle (250 ml = 250 cm³) contains more oil than required for initial installation.

The oil change frequency depends on how clean the measured gas is. The oil must be changed:

- at least every 7 years;
- immediately if the level on the sight glass (A) rises significantly (more than 3 mm above normal) due to moisture accumulation.

The correct filling level is in the centre of the level indicator (A). In case there are several oil level sight glasses on the meter, the reference sight glass (A) is always the lowest in the final installation position.

The amount of oil required for the different versions is shown in Tab.9.50:

Flange-flange gauge	Position with horizontal flow	Position with vertical flow
121 mm	15 cm ³	35 cm ³
171 mm	25 cm ³	120 cm ³
171 mm (Twin version) *	25 cm ³ + 25 cm ³	120 cm ³ + 120 cm ³
241 mm	60 cm ³	345 cm ³
241 mm (Twin version) *	60 cm ³ + 60 cm ³	345 cm ³ + 345 cm ³

* for the Twin version fill both the front and rear tanks

Tab. 9.50.

To change the oil, proceed as shown in Tab.9.51:

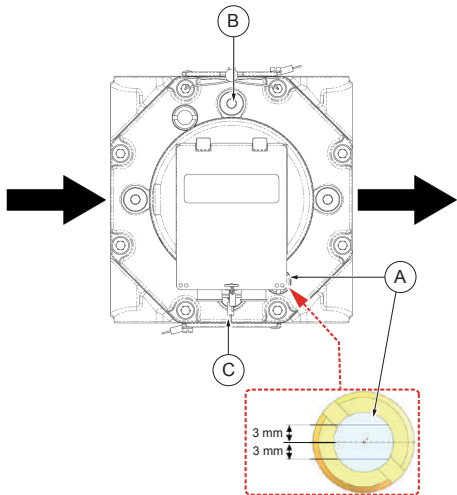
Step	Action	Image
1	Place a suitably sized container under the drain plug (C) to prevent oil from spilling onto the ground.	
2	Relieve the pressure.	
3	Open the filler cap (B) of the meter. Equipment required: 1/4" Allen key AF.	
4	Open the drain plug (C) of the meter and empty the tank completely, taking care that the oil falls into the container. Equipment required: 1/4" Allen key AF. ⚠ ATTENTION! Do not touch the oil.	
5	Replace the sealing o-ring of the drain plug (C).	
6	Close the drain plug (C). Equipment required: 1/4" Allen key AF.	
7	Fill the tank with the type of oil recommended by PIETRO FIORENTINI S.p.A. until the correct filling level indicated on the level indicator (A) is reached. ! NOTICE! The oil bottle is fitted with a spout.	
8	Replace the sealing o-ring of the filler cap (B).	
9	Close the filler cap (B). Equipment required: 1/4" Allen key AF.	
10	Dispose of the collected oil in the container. ! NOTICE! Used oil is highly toxic and should not be disposed of with household waste under any circumstances. When disposing of used oil, strictly observe the regulations in force in the country where the equipment is installed.	

Tab. 9.51.

! NOTICE!

Check the seals at the end of maintenance.

9.4 - SPECIAL MAINTENANCE

HAZARD!

Special maintenance:

- requires extensive and specialised knowledge of the machines, operations required, risks involved and correct procedures to operate safely;
- is reserved for qualified, trained, recognised and authorised technicians by PIETRO FIORENTINI S.p.A.

HAZARD!



It is forbidden to carry out extraordinary maintenance operations if the meter is pressurised or in operation. Before an extraordinary maintenance operation, check that:

- the equipment is in a safe condition:
 1. close the downstream shut-off valve;
 2. close the upstream shut-off valve;
 3. completely discharge the line.
- the pressure upstream and downstream of the equipment is “0”.

WARNING!

In case of doubt, do not perform any work. Contact PIETRO FIORENTINI S.p.A. for the necessary clarifications.

Special maintenance

Operator qualification	<ul style="list-style-type: none"> • Mechanical maintenance technician. • Installer. • Name of the user.
PPE required	<div style="text-align: center;">  </div> <div style="background-color: #f4a460; padding: 5px; margin-top: 5px;">  WARNING! </div> <p>The PPE listed in this table is related to the risk associated with the equipment. For the PPE required to protect against risks associated with the workplace, installation or operating conditions, please refer to:</p> <ul style="list-style-type: none"> • the regulations in force in the country of installation; • <u>any information provided by the Safety Manager at the installation facility.</u>
Equipment required	Refer to Chapter 7 'Commissioning/maintenance equipment'.

Tab. 9.52.

9.4.1 - UNINSTALLING THE METER

To uninstall the meter, proceed as shown in Tab.9.53:

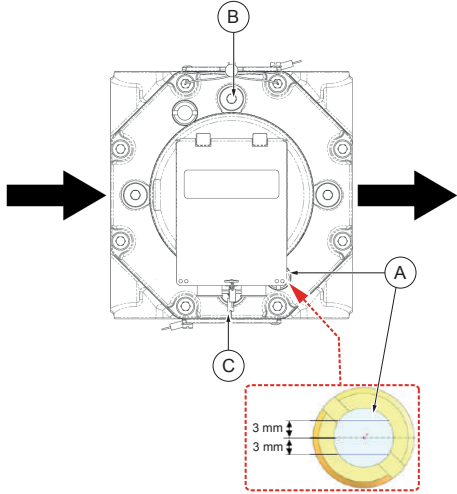
Step	Action	Image
1	<p>Check that the meter and the piping in which it is mounted are:</p> <ul style="list-style-type: none"> depressurised; at room temperature. <p>NOTICE!</p> <p>Take the necessary precautions to avoid the risks associated with the possible dispersion of residual fluid (toxic and flammable) in the pipes.</p>	
2	Disconnect the connection to the pulse emitters.	
3	Place a suitably sized container under the drain plug (C) to prevent oil from spilling onto the ground.	
4	<p>Open the filler cap (B) of the meter.</p> <p>Equipment required: 1/4" Allen key AF.</p>	
5	<p>Open the drain plug (C) of the meter and empty the tank completely, taking care that the oil falls into the container.</p> <p>Equipment required: 1/4" Allen key AF.</p> <p>ATTENTION!</p> <p>Do not touch the oil.</p>	
6	<p>First close the drain plug (C) and then close the filler cap (B).</p> <p>Equipment required: 1/4" Allen key AF.</p>	
7	Dispose of the collected oil in the container.	
8	Unscrew the bolts from the holes in the connecting flanges and remove them.	
9	<p>Remove the equipment from the installation line.</p> <p>NOTICE!</p> <p>For handling of the equipment, see Chapter 5 'Transport and Handling'.</p>	

Tab. 9.53.

HAZARD!

At a new installation of the meter, perform a new leak test.

WARNING!

Any re-installation of the meter requires the use of new seals, new o-rings and new and suitable mounting materials.

NOTICE!

See chapters 6 and 8 of this manual for installation and commissioning procedures.

10 - TROUBLESHOOTING

Below is a list of the cases (causes and services) that may occur over time in the form of malfunctions of various kinds. These situations depend on the conditions of the gas as well as on the natural ageing and wear of the materials.

10.1 - GENERAL WARNINGS

HAZARD!

Any maintenance work following the occurrence of a fault must be carried out by personnel:

- **trained on workplace safety also based on the regulations in force in the place of installation of the work equipment;**
- **qualified and authorised to carry out activities related to the equipment.**

WARNING!

PIETRO FIORENTINI S.p.A. shall not be held liable for any damage to people and property due to services:

- **other than those described;**
- **performed according to methods other than those specified;**
- **carried out by unsuitable personnel.**

NOTICE!

If an operating fault occurs and qualified personnel are not available for the specific intervention, call the Assistance Centre authorised by PIETRO FIORENTINI S.p.A.

10.2 - OPERATOR QUALIFICATION SPECIFICATION

Troubleshooting	
Operator qualification	<ul style="list-style-type: none"> • Mechanical maintenance technician. • Installer. • Name of the user.
PPE required	<div style="display: flex; align-items: center;">  </div> <div style="background-color: #f9a825; padding: 5px; margin-top: 5px;"> ⚠ WARNING! </div> <p>The PPE listed in this table is related to the risk associated with the equipment. For the PPE required to protect against risks associated with the workplace, installation or operating conditions, please refer to:</p> <ul style="list-style-type: none"> • the regulations in force in the country of installation; • any information provided by the Safety Manager at the installation facility.
Equipment required	Refer to chapter 7 "Equipment for commissioning/maintenance".

Tab. 10.54.

10.3 - TROUBLESHOOTING

NOTICE!

**Repair of defective meters is preferably carried out at the PIETRO FIORENTINI S.p.A. production plant
A new calibration will be carried out after the repair.**

During operation:

- Irregular rotation or blocking of the totalising unit may indicate mechanical damage;
- Excessive noise or vibration may indicate damage to bearings, internal rotors or internal gear wheels.

If the problem is limited to the totaliser unit, this can also be replaced without depressurising the system.

If a low-frequency pulse output does not seem to work or does not provide an indication consistent with the indicator, the pulse generator can be replaced without removing the totaliser unit.

NOTICE!

For the pulse generator or totaliser unit replacement procedure, contact PIETRO FIORENTINI S.p.A.

NOTICE!

Depending on the regulations of the country where the meter is installed, removing the seals may result in the meter being recalibrated.

For correct troubleshooting, it is necessary to proceed by first consulting the troubleshooting tables in section 10.4.

10.4 - TROUBLESHOOTING TABLES



See Chapter 4 'Description and Operation' for pictures of the meter IM-RM and its accessories.

Failure	Possible causes	Intervention
Meter does not register flow	Clogged line or meter.	Check the pipes and valves to make sure the gas can flow freely.
Low volume recorded	Oversized meter.	Check the meter size and flow rate.
	Friction within the meter.	Repair the meter (see Chapter 9 'Maintenance and Functional Checks').
High pressure drops	Deposits in the metering chambers.	Clean the meter.
	Worn bearings or wheels.	Repair the meter.
	Contaminated oil.	Change the oil.
Vibrations	Misaligned pipes or tension.	Eliminate misalignments or tension.
	Contamination in the metering chamber.	See Chapter 9 'Maintenance and Functional Checks'.

Tab. 10.55.

PAGE INTENTIONALLY LEFT BLANK

11 - UNINSTALLATION AND DISPOSAL

11.1 - GENERAL SAFETY WARNINGS

HAZARD!



Make sure that there are no potentially explosive ignition sources in the work area set up to uninstall and/or dispose of the equipment.

WARNING!

Before proceeding with uninstallation and disposal, make the equipment safe by disconnecting it from any power supply.

11.2 - QUALIFICATION OF THE OPERATORS IN CHARGE

Uninstallation and disposal

Operator qualification	<ul style="list-style-type: none"> Installer.
PPE required	<div style="display: flex; align-items: center;">  </div> <div style="background-color: #f9a825; padding: 5px; margin-top: 5px;">  WARNING! </div> <p>The PPE listed in this table is related to the risk associated with the equipment. For the PPE required to protect against risks associated with the workplace, installation or operating conditions, please refer to:</p> <ul style="list-style-type: none"> the regulations in force in the country of installation; any information provided by the Safety Manager at the installation facility.
Equipment required	Refer to Chapter 7 'Commissioning/maintenance equipment'.

Tab. 11.56.

11.3 - UNINSTALLATION

ATTENTION!

Before uninstalling, discharge and completely drain the fluid in the line and inside the equipment.

To properly uninstall the equipment, proceed as specified in Tab. 11.57.:

Step	Action
1	Close the valves upstream and downstream of the equipment.
2	Depressurise the line then disconnect the upstream and downstream piping to the equipment by unscrewing the fittings with suitable hand tools.
3	Remove the equipment. <div style="border: 1px solid blue; padding: 5px; margin-top: 5px;">  NOTICE! </div> <p>Seal the valves upstream and downstream of the equipment if:</p> <ul style="list-style-type: none"> closing the system; the equipment is not replaced immediately.

Tab. 11.57.

11.4 - INFORMATION REQUIRED IN CASE OF RE-INSTALLATION

NOTICE!

Should the equipment be reused after uninstallation, refer to:

- Chapter 6 'Installation';
- Chapter 8 'Commissioning'.

11.5 - DISPOSAL INFORMATION

NOTICE!

- **Correct disposal avoids harm to man and the environment and allows valuable raw materials to be reused.**
- **The regulations in force in the country where the equipment is installed must be strictly observed.**
- **Unauthorised or incorrect disposal will result in the application of the sanctions provided for by the regulations in force in the country of installation.**

The equipment was manufactured with materials that can be recycled by specialised companies.
For proper disposal of the equipment, proceed as specified in Tab. 11.58:

Step	Action
1	Set up a large work area free from obstacles where to safely dismantle the equipment.
2	Sort the various components by type of material for easier recycling through separate collection.
3	Send the materials obtained in Step 2 to a specialised company.

Tab. 11.58.

11.5.1 - EQUIPMENT MATERIALS

The equipment in any configuration consists of the materials described in Tab.11.59.:

Material	Present in	Disposal/recycling indications
<ul style="list-style-type: none"> Aluminium alloy (anodised and non-anodised) Ductile iron 	<ul style="list-style-type: none"> Meter body and cover Rotors 	Disassemble and collect separately. Recycle through the appropriate centres.
Carbon steel	Gears	Disassemble and collect separately. Recycle through the appropriate centres.
Stainless steel	<ul style="list-style-type: none"> Bearings Shafts Hybrid connector 	Disassemble and collect separately. Recycle through the appropriate centres.
Synthetic materials	Gears	Disassemble and collect separately. Recycle through the appropriate centres.
<ul style="list-style-type: none"> Polycarbonate Plastic material 	Totaliser group	It must be collected and disposed of separately.
Lubricants/Oils	-	They must be collected and delivered to the appropriate specialised and authorised collection and disposal centres.
Pneumatic/electric components	-	They must be collected and delivered to the appropriate specialised and authorised collection and disposal centres.

Tab. 11.59.

NOTICE!

The above materials refer to standard versions. Different materials can be provided for specific needs.

PAGE INTENTIONALLY LEFT BLANK

12 - RECOMMENDED SPARE PARTS

12.1 - GENERAL WARNINGS

NOTICE!

If spare parts not marked are used, PIETRO FIORENTINI S.p.A. their declared performance cannot be guaranteed.

It is recommended to use only original PIETRO FIORENTINI S.p.A. spare parts

PIETRO FIORENTINI S.p.A. shall not be held liable for any damage caused by using non-original parts.

12.2 - HOW TO REQUEST SPARE PARTS

NOTICE!

For specific information, please refer to the sales network of PIETRO FIORENTINI S.p.A.

12.3 - SPARE PARTS LIST

Reference to the spare parts order codes:

Code	Component
Contact PIETRO FIORENTINI S.p.A. with the meter serial number on the identification plate	Full totaliser
	Pulse emitter
Shell Morlina 10 + colour agent C.I.26000	Lubricating oil
TDO60257	100 ml bottle of oil
TDO60258	250 ml bottle of oil
7070-1010-2008	Oil plug o-ring (filling and draining)

Tab. 12.60.

TM0073ENG

